



Too Big to Govern

Public Balance Sheet for the World's Largest Store

November 2019



ECONOMIC
ROUNDTABLE

Knowledge for the Greater Good

Cover image:

Falling Phaeton, from The Four Disgracers

Hendrick Goltzius

1588

Met Museum

Phaeton tumbles towards the sea, his body twisting; parts of a chariot and four horses also hurtle downwards after trying to enter the realm of the gods.

Too Big to Govern

Public Balance Sheet for the World's Largest Store

November 2019

Economic Roundtable

Daniel Flaming

Patrick Burns

Underwritten by the
Los Angeles County Federation of Labor

Report available at: www.economicrt.org

This report has been prepared by the Economic Roundtable, which assumes all responsibility for its contents. Data, interpretations and conclusions contained in this report are not necessarily those of any other organization.

This report can be downloaded from the Economic Roundtable web site:
www.economicrt.org

Follow us on Twitter [@EconomicRT](https://twitter.com/EconomicRT)
Like us on Facebook.com/EconomicRT

Acknowledgements

We would like to express our gratitude to the organizations that generously provided information and insights that made this study possible.

LABOR ORGANIZATIONS

American Federation of Musicians Local 47
Inland Empire Labor Council
International Brotherhood of Electrical Workers Local 40
International Brotherhood of Teamsters
International Longshore and Warehouse Union
Los Angeles County Federation of Labor
Los Angeles/Orange Counties Building and Construction Trades Council
National Association of Letter Carriers
National Association of Letter Carriers Branch 24
Teamsters Local 396
United Food and Commercial Workers Local 770
Warehouse Worker Resource Center
Workers United, SEIU

GOVERNMENT ORGANIZATIONS

City of Commerce
City of Eastvale
City of Fontana
City of Irvine
City of Moreno Valley
City of Rancho Cucamonga
City of Redlands
City of Redondo Beach
City of Rialto
City of Santa Monica
City of Vernon
March Joint Powers Authority
Ontario International Airport
State of California Film Commission
State of California Office of Business and Economic Development

Table of Contents

- Executive Summary.....1

- I. The World's Biggest Store7
 - Overview.....8
 - Amazon's Footprint.....9
 - Summary14

- II. Amazon's Customers.....15
 - Total Sales.....16
 - Amazon Sales by Neighborhood.....18
 - Summary21

- III. Logistics.....23
 - Transporting Goods to Fulfillment Centers and then to Homes.....24
 - Fulfillment Center Warehouses25
 - Transportation Impacts.....26
 - Logistics Employment.....30
 - Summary32

- IV. Warehouse Workers.....33
 - Profile of Warehouse Workers34
 - Where Workers Live.....36
 - Earnings and Public Benefits.....38
 - Poverty and the Wage Deficit.....42
 - Housing Conditions.....45
 - Summary46

- V. Public Records Act Requests.....49
 - Public Decisions about Amazon50
 - Environmental Impact Reports52

Absence of Tax Benefits.....	56
Summary	57
VI. Amazon in Silicon Beach and Hollywood.....	59
Amazon Technology and Entertainment in SoCal.....	60
Economic Impacts of Amazon in Southern California.....	61
Occupations of Amazon’s Silicon Beach and Hollywood Workforce.....	64
Summary	67
VII. Public Balance Sheet.....	69
Amazon’s Annual Profit and Commitment to Employees.....	70
Recommendations	74
VIII. End Notes.....	77



Executive Summary

Amazon is flourishing as a corporation. On good days in the stock market it is worth \$1 trillion, making it most valuable company on the planet. Amazon has come of age financially. This report examines its standing as a socially accountable corporate citizen, with close attention to the impact of Amazon's logistics operations on the public balance sheet in the four-county Los Angeles region. This region purchased an estimated \$7.2 billion in goods from Amazon in 2018.

Amazon's trucks hauled an estimated 15.5 billion ton-miles of truck cargo in the region last year, altering how land is used, making heavy use of the transportation infrastructure, affecting air quality, and shaping the economic and living conditions of workers and their families.

Amazon's warehouses have been welcomed by some communities as a source of jobs and economic growth, but there has not been an assessment of the costs of its presence. As with individuals, communities that have come of age are able to make decisions that shape their own future and safeguard their own well-being. The most successful cities take purposeful action to influence the economy in ways that help workers earn sustaining livelihoods.

Amazon's customers are concentrated in affluent coastal and hillside neighborhoods, but warehouses and workers are concentrated 60 to 70 miles away in struggling working class communities. This geographic divide reflects the economic polarization and structure of privilege in the four-county region. And public infrastructure and local communities bear the financial and environmental costs of trucking goods from ports to warehouses to consumers. Truck routes from ports to warehouses traverse low-income communities of color, adversely affecting air quality and health in those communities.

The popularity of Amazon attests to its excellent customer care. This report provides a balance sheet from the public perspective to support greater transparency in fiscal policy, broader risk assessment, and financial equity with the employees and communities that drive its profitability.

Impacts on the Land and Air

Every day, ships, trucks, trains, and airplanes bring an estimated 21,500 diesel truck loads of merchandise to and from 21 Amazon warehouses in the four-county region. In total, Amazon's trucking operations in the four-county region in 2018 created an estimated \$642 million in uncompensated public costs for noise, road wear, accidents, and harmful emissions.

With an average of 2,180 miles traveled per flight, Amazon's flights into and out of airports in Riverside and San Bernardino counties released an estimated 620,000 metric tons of CO₂ into the atmosphere in 2018. The climate change resulting from those emissions creates an estimated \$45

million in social costs for impacts on agricultural productivity, human health, flooding, and ecosystem services.

Impacts on Workers

Amazon's intense, demanding corporate culture has benefited those at the top, but not necessarily workers who do the heavy lifting of the logistical network that brings packages to our homes. Proximity to lower-income neighborhoods in the four-county region facilitates Amazon's access to a job-hungry labor force. At the same time, the wages paid by Amazon perpetuate the economic struggle in these neighborhoods.

Amazon's warehouse jobs are grueling and high-stress. Customer orders must be assembled and delivered on rapid schedules. Warehouse workers wear tracking devices that management uses to monitor where they are at any time, how many steps they take to get their packages assembled, and how long it takes to pick up each item. Those who can't meet the assembly quotas are terminated.

Most logistics employees are working full-time to support their families but 86 percent earn less than the basic living wage for Riverside and San Bernardino counties. The typical worker had total annual earnings in 2017 of \$20,585, which is slightly over half of the living wage. Fourteen percent were under the federal poverty threshold and another 31 percent were just above the poverty threshold.

For every \$1 in wages paid by Amazon, warehouse workers receive an estimated \$0.24 in public assistance benefits. The average annual amount of public benefits per worker is \$5,245. The biggest component of public benefits is subsidized health insurance.

Public benefit amounts remain high even for full-time warehouse workers. Workers who were at the job 2,080 hours a year (40 hours a week, 52 weeks a year) received an average of \$5,094 in benefits to make up the deficit in the basic needs of their families that were not met by their wages.

As a consequence of having low wages and insufficient incomes to afford adequate homes for their families, 57 percent of Amazon warehouse workers live in housing that is overcrowded and substandard. There is direct and indirect evidence of significant homelessness among warehouse workers.

The economic condition of logistics worker contrasts starkly with workers employed in Silicon Beach and Hollywood in entertainment, computer and mathematics jobs. These workers make a living wage and earn enough to afford housing and buy Amazon products. The higher standard of living they enjoy demonstrates that when the job market or the regulatory environment requires it, Amazon can afford to pay sustainable wages.

Public Oversight

Public Records Act requests were submitted to 39 public jurisdictions where Amazon facilities are located. Nineteen jurisdictions said they had no records related to Amazon. This includes the cities of *Jurupa Valley*, *Riverside* and *San Bernardino* where Amazon has large warehouse facilities and *Culver City* where Amazon has a major movie production studio.

Seven cities completed environmental impact reports (EIRs), which represent the highest level of local policy analysis regarding Amazon's impacts. These EIRs supported development of over 36 million square feet of warehouse space and up to 89 plane flights a day. No impacts on the environment, transportation infrastructure or human well-being were identified that warranted stopping a project. Often job creation was identified as the reason for proceeding with a project.

The only benefits that cities are receiving from Amazon's warehouses are from construction jobs and fees, and employment of residents in low-wage warehouse jobs, along with modest, trickle-down multiplier effects as they spend their sparse earnings. Cities do not receive sales tax revenue from the sale of goods in these warehouses.

The "overriding consideration" put forward in EIRs, that Amazon's warehouses would provide good jobs and strengthen the economy, does not stand up to scrutiny. This report shows that Amazon's trucks cause extensive uncompensated damage to public roads and Amazon's warehouse jobs pay so little that workers can't afford adequate housing and rely on public assistance. The substandard housing conditions of Amazon's warehouse workers and their inability to afford food or healthcare for their families weaken the economies of cities.

Public Balance Sheet

Public tools for assessing and regulating Amazon's impacts are inadequate. The available policy review tools are used infrequently, look only at fragments of Amazon's local impacts, and show a strong pro-development bias.

A new oversight structure is needed to assess the risk and impacts of Amazon's activities, and to establish regulatory standards that require the public balance sheet from Amazon's operations to pay its full costs to the public and to employees.

Controversy has surfaced about Amazon's scant corporate income tax payments and whether it is contributing adequately to the general welfare. Over the past decade, Amazon has paid less than three percent of its \$27 billion in profits for federal income tax.

This report uses publicly available data to estimate Amazon's impacts. The directional findings are sound and often conservative, with methods and sources referenced throughout. Amazon is a data-rich organization with extensive information about wages, working conditions, public subsidies, logistics operations, and carbon footprint. We recommend that Amazon collaborate in improving the accuracy of this public balance sheet.

Amazon has received nearly \$850 million in public subsidies in the four-county region, some documented in public records, others estimated. This includes:

- \$3 million for building construction
- \$25 million for movie production
- \$30 million for city waivers of traffic impact fees
- \$45 million annually for climate change impacts from cargo aircraft flights
- \$98 million annually in public assistance for warehouse workers
- \$647 million annually in uncompensated public costs for warehouse trucking

This is only a partial list, for example, it doesn't include public costs to offset the wage deficits of underpaid delivery drivers employed by Amazon and its subcontractors.

Only 7 percent of the public subsidies that Amazon has received are one-time outlays. The other 93 percent of subsidies are ongoing and will recur year-after-year until Amazon raises wages and lowers greenhouse gas emissions.

American society expects that adults will pay their own way in the world, clean up their messes, and reciprocate what others do for them. These expectations are reasonable for corporate citizens as well.

Amazon has grown explosively as an autonomous, fresh thinking, hard driving organization that has taken maximum advantage of every freedom and opportunity allowed it. But it is no longer just an agile adventurer. Amazon is now a dominant force in shaping communities where its logistics operations are located and its workers live. It is restructuring industries, destroying brick-and-mortar retail jobs and replacing them with warehouse and delivery jobs.

Phaeton (*cover image*) did not know his limits, overreached and fell to his own destruction. Amazon can avoid this fate by finding its footing as an equitable community partner and continue to rise both as an economic success and a corporate citizen.

It is time for Amazon to come of age and pay its own way. This means paying its full costs to the communities that host it and the workers who create its profits. Amazon will benefit when its workers have living

incomes because they will have the buying power to purchase the products it sells.

Recommendations

Based on the findings in this report, the Economic Roundtable makes the following nine recommendations for achieving equity in Amazon's logistics operations:

1. Pay a minimum wage of \$20 an hour, adjusted annually for cost of living changes, to provide a living income for warehouse workers and delivery drivers.
2. Provide comprehensive and affordable health insurance for warehouse workers and delivery drivers and their families, eliminating the need for workers and their families to rely on publicly subsidized Medi-Cal health insurance.
3. Provide work breaks for warehouse workers that enable them to remain hydrated, use bathrooms and eat mid-shift meals.
4. Provide affordable child care onsite or at nearby child care centers.
5. Require logistics subcontractors to provide the same wage floor and benefits as Amazon.
6. Invest Amazon's assets in building affordable housing in communities where its logistics facilities are located as well as the communities where employees from those facilities live.
7. Become a partner in local, regional and statewide initiatives to raise the wage floor for the entire logistics sector so that all warehouse, trucking and delivery companies meet the same standards of civic responsibility as Amazon.
8. Step up as a leader in reducing climate change impacts by deploying zero emission vehicles and disclosing its full carbon footprint.
9. Collaborate in improving and expanding the scope of impact estimates provided in this report to support analysis, planning and policies for reducing the costs and increasing the benefits of the services Amazon provides.



1. The World's Biggest Store

Overview

Americans trust Amazon more than any other institution except the military, according to a reliable survey.¹ Another survey found that Americans are more likely to recommend Amazon to their family and friends than any other large tech company.² Americans' confidence in Amazon has been built one package at a time, hundreds of millions of times over.

On good days in the stock market, Amazon is worth \$1 trillion, making it most valuable company on the planet.

On good days in the stock market, Amazon is worth \$1 trillion, making it most valuable company on the planet.³ While Amazon has come of age financially, its standing as a corporate citizen that is socially accountable to the public is less examined. This report describes the full scope of Amazon's activity and focuses specifically on its logistics operations to provide an assessment its impact on the public balance sheet in the four-county Los Angeles region. This region purchased an estimated \$7.2 billion in goods from Amazon in 2018.⁴

Amazon is disrupting established industries including the retail, transportation and logistics sectors. Dun & Bradstreet says, "Amazon.com's strategy seems simply to be more. More industries, more products, more services, more (and faster) delivery options that lead to more customers, more revenue, and more profit."⁵ Amazon reports that they employed 647,500 full-time and part-time employees as of December 31, 2018, plus additional independent contractors and temporary personnel.⁶

In the Los Angeles region Amazon's growing presence includes a large contingent of workers with boots on the ground – logistics workers who move nearly 8,000,000 truckloads of cargo a year from the Port of Long Beach to warehouses in the Inland Empire (Riverside and San Bernardino counties), where the inventory of the world's biggest store is sorted and delivered to homes in the region or shipped on to other U.S. cities.

Amazon is flourishing as a corporation, stating, "We will work hard to spend wisely and maintain our lean culture."⁷ This intense, demanding corporate culture has benefited those at the top, but not necessarily workers who do the heavy lifting of bringing packages to our homes or the communities where they work and live.

As with individuals, communities that have come of age are able to make decisions that shape their own future and safeguard their own well-being. One critical measure of civic maturity is taking purposeful action to influence the economy in ways that enable people like warehouse workers who do hard work that we depend on to earn sustaining livelihoods.

Action is needed when workers whose energy and long hours drive corporate prosperity are surviving at the margins of the economy, struggling to pay rent and build better lives for their children.

Amazon's Footprint

Amazon owns over 40 subsidiaries. Most are in the technology and electronic retail sectors, but others include manufacturing, transportation, retail food, and even forays into services such as home repair and house cleaning. Thumbnail sketches of ten of Amazon's most prominent business activities in the Los Angeles region are provided below.

Fulfillment Centers

Twenty-one warehouses in the Los Angeles region with over fifteen million square feet of space are part of the Fulfillment by Amazon (FBA) platform. FBA manages warehousing, inventory management and pick-n-pack. These facilities are being developed to support Amazon's rapidly growing e-commerce sales. The goal is 24-hour delivery.



Local Delivery Network

Most cities and communities in the Los Angeles region have local fulfillment and delivery centers, which receive goods from warehouses, load them into vans and other modes of delivery, including by foot, and transport them to the homes and businesses of consumers. Delivery service is carried out by a mix of U.S. Postal Service letter carriers, United Parcel Service delivery drivers,





Amazon Flex independent contractors who create a large but less visible second tier of Amazon jobs.

Amazon Nationwide Logistics Corporation

Amazon's freight brokerage and forwarding business provides trucking and delivery services within the Amazon

freight network. This branch of Amazon subcontracts trucking and delivery services to independent contractors, creating a large second tier of trucking employment and goods movement. It matches truck drivers with shippers, deepening its presence in the "middle mile" logistics space, which handles the paperwork, phone calls and trucking to arrange deliveries between shipping docks or warehouses.

Amazon Maritime

Amazon offers ocean freight services. The official name on the Federal Maritime Commission Registry is Beijing Century JOY Courier Service Co. Ltd., with the trade name "Amazon China." Amazon imported

123,000 twenty-foot equivalent cargo containers into the U.S. in 2018 through the ports of Long Beach and Los Angeles.⁸

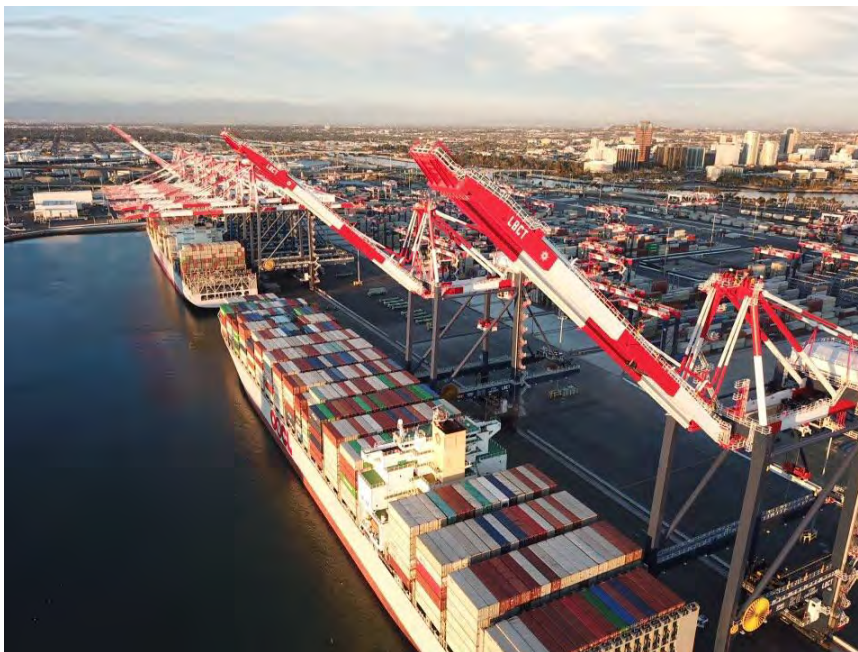

More than 75 percent of all cargo imported through the ports of Long Beach and Los Angeles is taken 65 miles east to warehouses in the Inland Empire. Amazon has a significant trucking

footprint and significant public costs in moving goods to the Inland Empire.

Amazon Air

Amazon Air is a cargo airline operating exclusively to transport Amazon packages. By 2021, Amazon Air is projected to have at least 70 cargo aircraft operating out of over 20 air gateways in the United States. It currently leases 48 aircraft from Atlas Air, Air Transport Services Group, and Southern Air.⁹ Air freight for the Los Angeles region is delivered to Ontario International Airport, San Bernardino International Airport and March Air Force Base, all of which are near Amazon's Inland Empire warehouses.



Rail Transportation

Some of Amazon's ocean-transported cargo coming through the sort of Long Beach and Los Angeles is transported by rail to intermodal warehouse facilities in Wilmington, San Pedro and Long Beach, California. With little or no storage, the contents of sea cargo containers are dissembled and sorted onto pallets that are transported by truck to warehouse fulfillment centers in the L.A. region and beyond to distribution hubs in Chicago, Texas and other Amazon locations. Some truck trailers are transported to other regions on railroad flatcars. In addition, some cargo containers are transported to other regions by rail without being repacked.



Whole Foods

Whole Foods Market supermarket chain is owned by Amazon, which exclusively sells products free from hydrogenated fats and artificial colors,



flavors, and preservatives. A USDA Certified Organic grocer in the United States, the chain is popularly known for its organic selections. Whole Foods has 500 stores in North America and the United Kingdom, and 91 stores in the four-county Los Angeles metropolitan region. Whole Foods markets are supported by a network of refrigerated trucks and warehouses in the Los Angeles region.



Amazon Fresh

Amazon Fresh is a grocery delivery and pickup service that operates mainly with Whole Foods Market. Customers log in online and select the grocery items they want to purchase, and a date, time and location for delivering their order.



Amazon Web Services

Amazon Web Services (AWS) provides on-demand cloud computing platforms and application program interfaces (APIs) at server farms throughout the world on a metered pay-as-you-go basis. In aggregate, these cloud computing web services provide a set of primitive abstract technical infrastructure and distributed computing building blocks and tools.

AWS's version of virtual computers emulate most of the attributes of a real computer including, hardware central processing units and graphics processing units for processing, local/RAM memory, hard-disk storage; a choice of operating systems; networking; and pre-loaded application software such as web servers, databases, and customer relationship management. AWS is a leader in artificial intelligence. It provides 42 percent of all internet cloud storage services in the world and produces roughly half of Amazon's profits.¹⁰

Amazon Entertainment

Amazon's digital entertainment products enable customers to access apps and games, and stream or download movies, TV shows, books, and music.

Amazon Studios is located in Culver City, California and is a television and film producer and distributor. It specializes in developing television series and distributing and producing films. Content is distributed through theaters and Prime Video, Amazon's digital video streaming service.



Amazon dominates the production and distribution of audio books, with much of this work done in the West Los Angeles area. These subsidiaries include *Audible.com* and *Brilliance Audio*.

Amazon Surveillance Technology

Amazon Rekognition is a cloud-based computer vision platform that can be used to identify faces of known people, compare faces, and find similar faces in a database. It can also be used to detect facial attribute in images, including gender, age, and emotions. This technology has been offered to the U.S. Department of Homeland Security

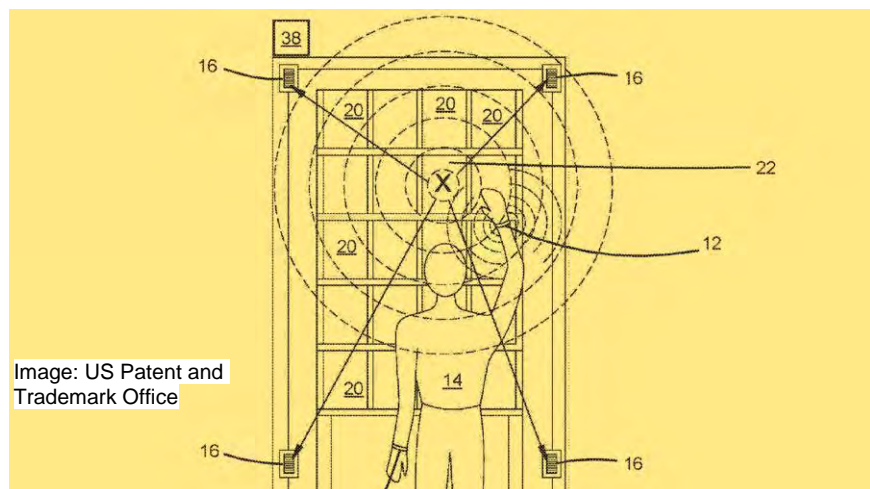

Immigration and Customs Enforcement agency and to some police departments.¹¹

Technology to monitor and time human activity is used in Amazon's highly automated warehouses through the scan guns carried by workers. The scan guns direct workers to each item they are to collect, then immediately give them a new one and started counting down the seconds left to do it. Amazon has recently patented wristbands (illustration from Amazon's patent shown here) that track where a given warehouse workers' hands are at all times.¹²

Amazon alters how land is used, makes heavy use of public roads, affects air quality, and shape the economic and living conditions of workers and their families.

Summary

Amazon's business activities have multiple impacts on the Los Angeles region, particularly the movement of goods by its logistics sector. In addition to providing goods and services that consumers need and appreciate, Amazon's activities alter how land is used, create an imprint on the transportation infrastructure, affect air quality, and shape the economic and living conditions of workers and their families.

This report quantifies these outcomes to provide a holistic understanding of Amazon's impact on the Los Angeles region. This is a balance sheet from the public perspective, bringing together comprehensive information about the benefits and costs of Amazon's presence to support transparency in fiscal policy making and deeper risk assessment.



2. Amazon's Customers

Total Sales

In 2018 Amazon had estimated annual sales of over \$7.2 billion in the four-county region of Los Angeles, Orange, Riverside and San Bernardino, as shown in *Figure 1*.¹³ This represents 5.3 percent of Amazon's \$141.4 million in U.S. e-commerce sales in 2018,¹⁴ not including revenue generated in the four-county region from users of Amazon Web Services (AWS) or the production of movies and other entertainment content, which is centered in Culver City and Santa Monica.

The non-food retail items sold by Amazon and other retailers account for roughly 16 percent of household expenditures. Food and alcoholic beverages consumed at home account for another 8 percent of household expenditures, and Amazon is gaining traction in that market as well. Amazon supplies an estimated 13 percent of non-food retail items for households in the four-county region.

In 2018 Amazon had estimated annual sales of over \$7.2 billion in the four-county region

Figure 1: Estimated Value of Amazon Sales in 2018 by County

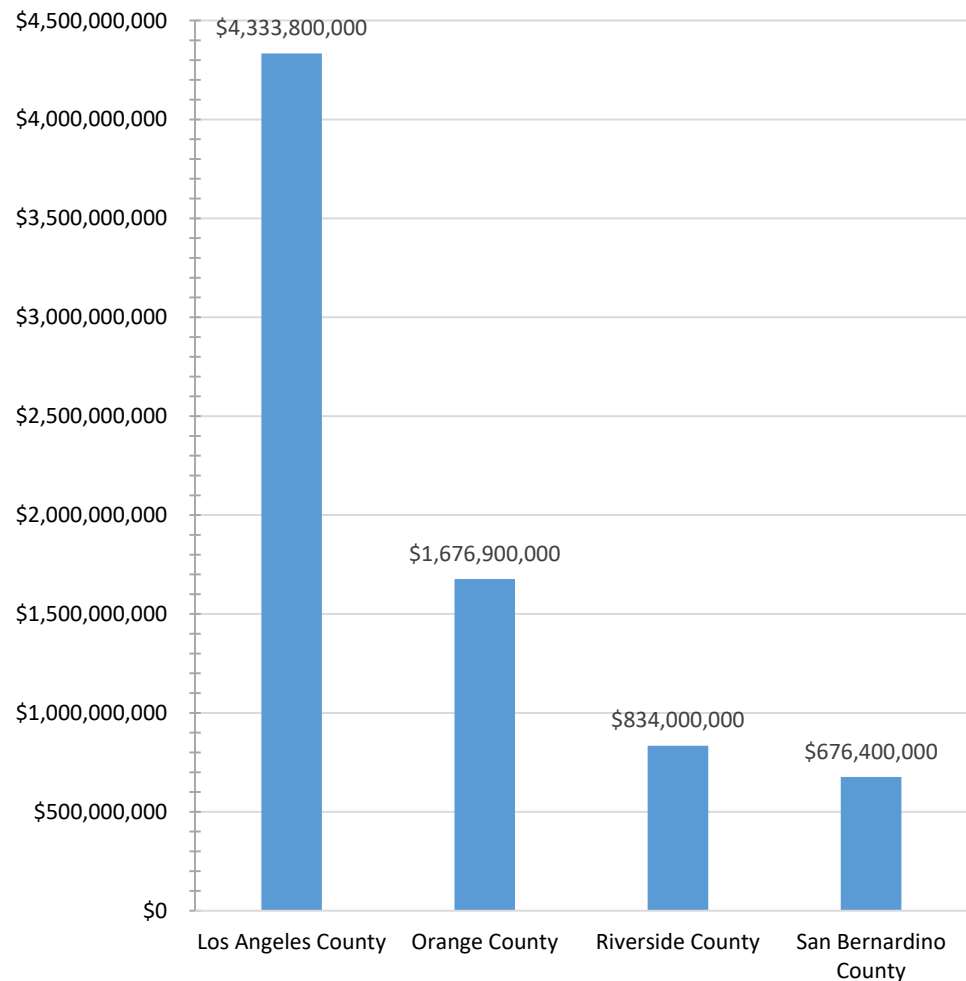

Source: Derived from U.S. Census Bureau American Community Survey 2013-2017 household income data, U.S. Bureau of Labor Statistics Household Consumption breakout of household consumption by item and income level, and Amazon e-commerce sales in the U.S. in 2018.

Amazon had an estimated \$4.3 billion in non-food e-commerce sales in Los Angeles County in 2018, \$1.7 billion in Orange County, \$834 million in Riverside County, and \$676 million in San Bernardino County.

The amount and remarkable growth rate of Amazon’s sales is altering the region’s industry structure, job market and transportation infrastructure.

Amazon’s sales per household vary widely and are linked to level of household income, as shown in *Figure 2*, which shows estimated annual household purchases from Amazon in 2018 for the 40 largest cities in the four-county region.

The average household spent an estimated \$1,330 on e-commerce items from Amazon in 2018. The lowest household purchases among these large cities were in San Bernardino, where households purchased an estimated average of \$883 in non-food items from Amazon in 2018. At the high end of the range, households in Newport Beach spent an estimated average of \$2,001 for items from Amazon.

The average household spent an estimated \$1,330 on e-commerce items from Amazon in 2018.

Figure 2: Estimated Amazon Sales per Household in the 40 Largest Cities in the Los Angeles Metropolitan Area

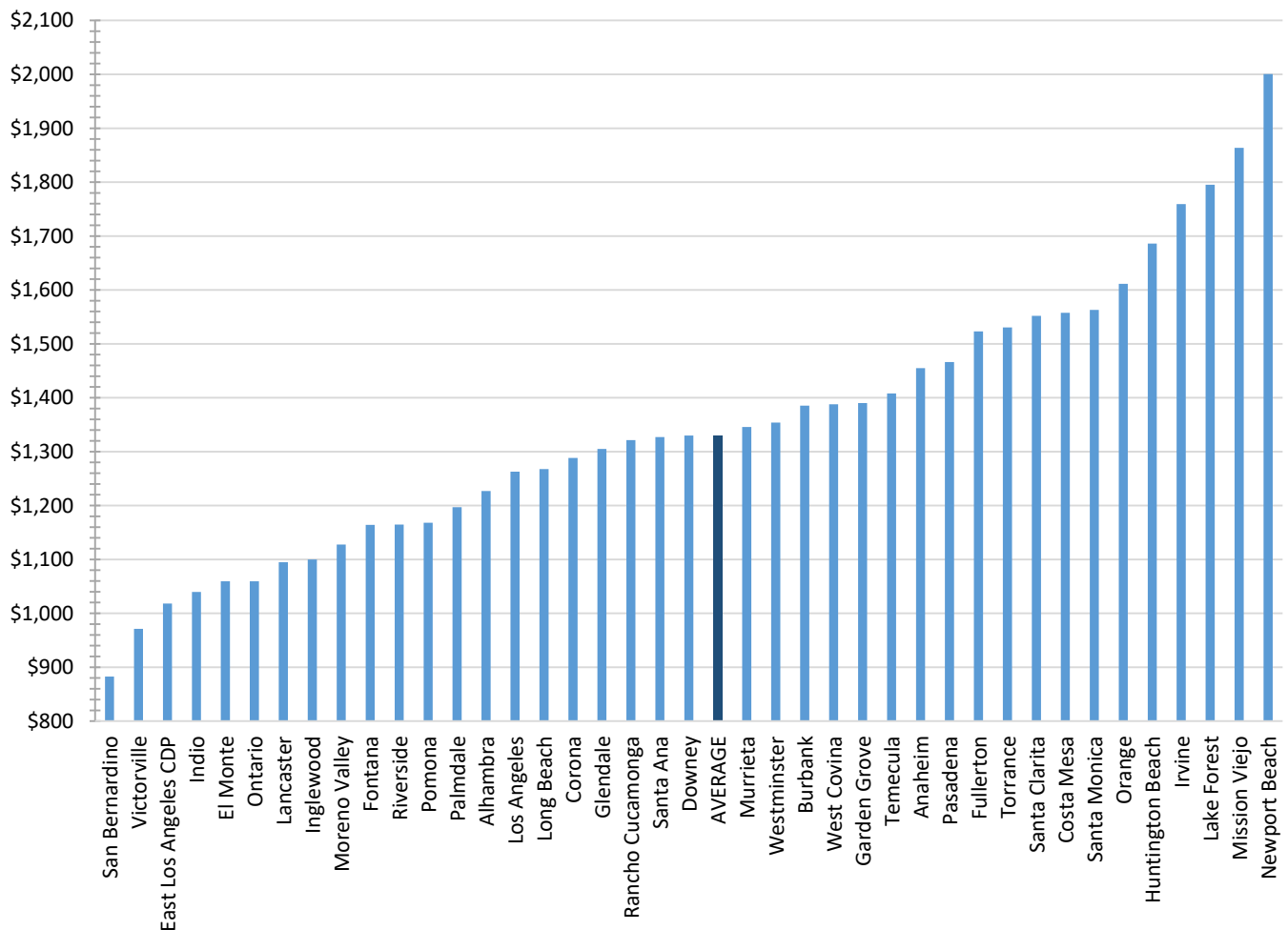

Source: Derived from U.S. Census Bureau American Community Survey 2013-2017 household income data, U.S. Bureau of Labor Statistics Household Consumption breakout of household consumption by item and income level, and Amazon e-commerce sales in the U.S. in 2018.

Total sales in each city are the result of both population size and household income. Los Angeles is the largest city, with roughly 1.4 million households that made an estimated \$1.7 billion in purchases from Amazon. At the other end of the scale, the industrial city of Vernon, with 24 households, made an estimated \$32,000 in purchases from Amazon.

Amazon Sales by Neighborhood

The estimated average amount of household purchases from Amazon in each census tract in 2018 is shown in *Figure 3*. These purchase levels are closely associated with household income in each tract. The darkest shade of brown shows tracts in which the average household made \$2,000 or more in e-commerce purchases from Amazon. These tracts are located in

Figure 3: Estimated Average Amazon Sales per Household

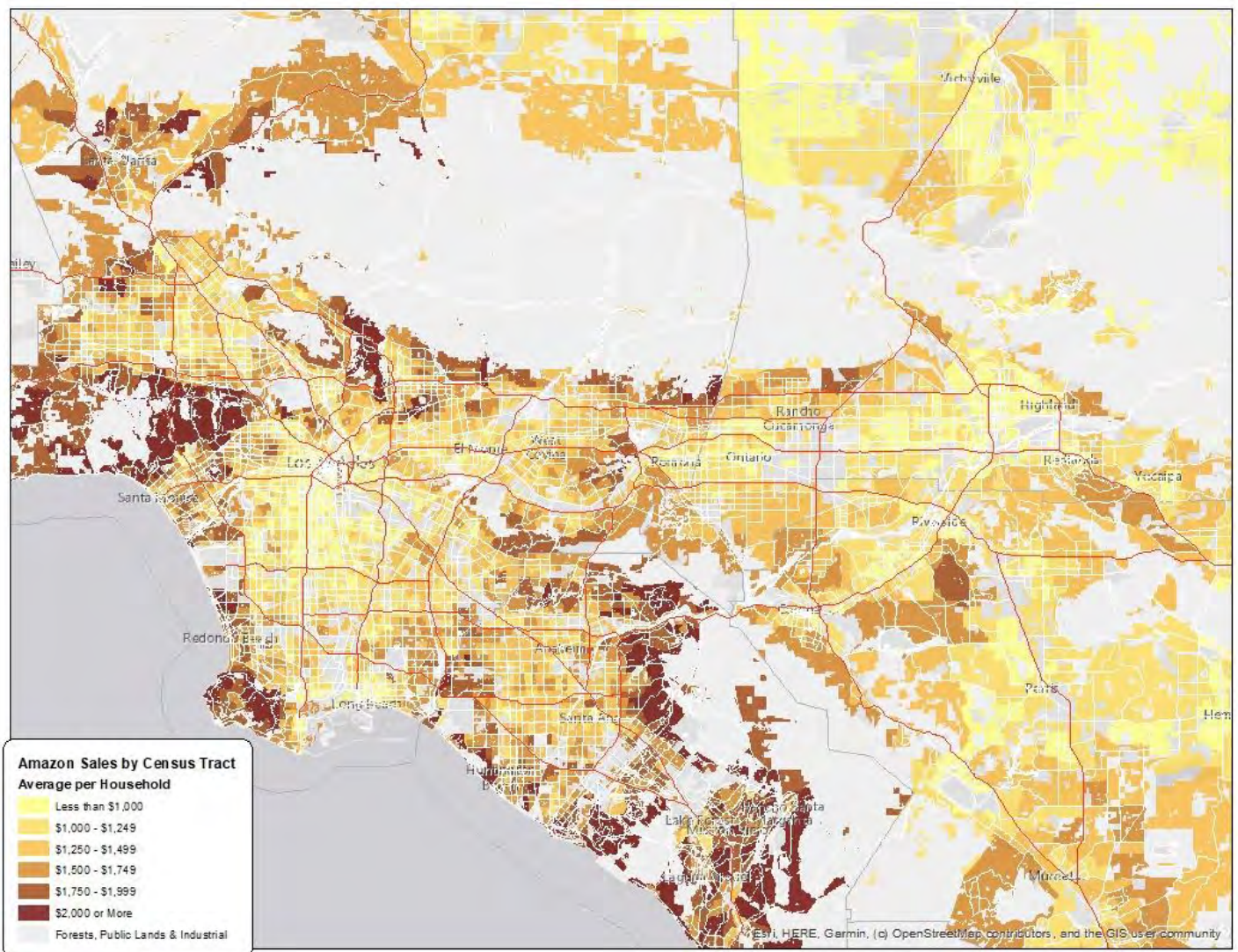

Source: Derived from U.S. Census Bureau American Community Survey 2013-2017 household income data, U.S. Bureau of Labor Statistics Household Consumption breakout of household consumption by item and income level, and Amazon e-commerce sales in the U.S. in 2018.

affluent coastal and foothill areas. At the low end of spending levels, tracts that spent less than \$1,000 with Amazon are shown in yellow. These tracts are located in lower-income flatland areas. Many are located south of downtown Los Angeles and in San Bernardino County.

Total estimated e-commerce purchases from Amazon in each census tract are shown in *Figure 4*. The Census Bureau typically creates tract boundaries that encompass about 4,000 people, although the actual population in each tract varies.

Some tracts are estimated to have had aggregate purchases from Amazon exceeding \$3 million. These tracts are shown in the darkest shade of brown and are located in more densely populated affluent neighborhoods. At the low end of spending, some tracts are estimated to have had less than \$1,000,000 in purchases from Amazon. These tracts are shaded yellow and

Figure 4: Estimated Total Amazon Sales per Census Tract

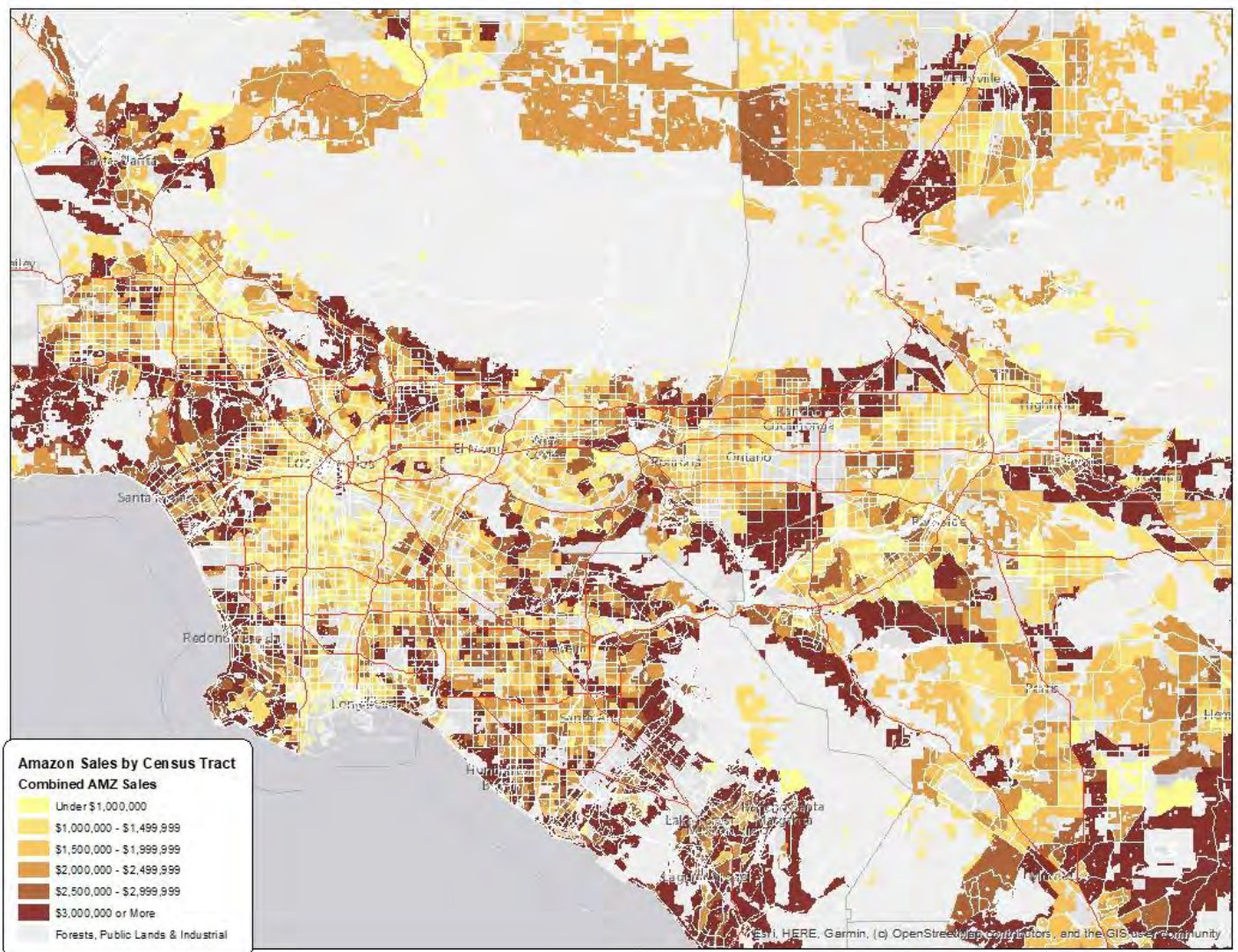

Source: Derived from U.S. Census Bureau American Community Survey 2013-2017 household income data, U.S. Bureau of Labor Statistics Household Consumption breakout of household consumption by item and income level, and Amazon e-commerce sales in the U.S. in 2018.

are located in low-income neighborhoods. Many of these neighborhoods are located south of downtown Los Angeles and in the southern part of San Bernardino County.

Whole Foods

Amazon purchased the Whole Food grocery store chain in 2017, giving it 91 brick and mortar grocery stores under the of Whole Foods and Whole Foods 365 brands in the four-county region. Los Angeles County has 53 stores, Orange 24, Riverside 7, and San Bernardino 7. This represents 18 percent of all Whole Foods stores.

Whole Foods markets are located in or adjacent to the highest income census tracts, as can be seen in *Figure 5*, which shows store locations in the

Figure 5: Whole Foods Markets in the Four-County Study Area

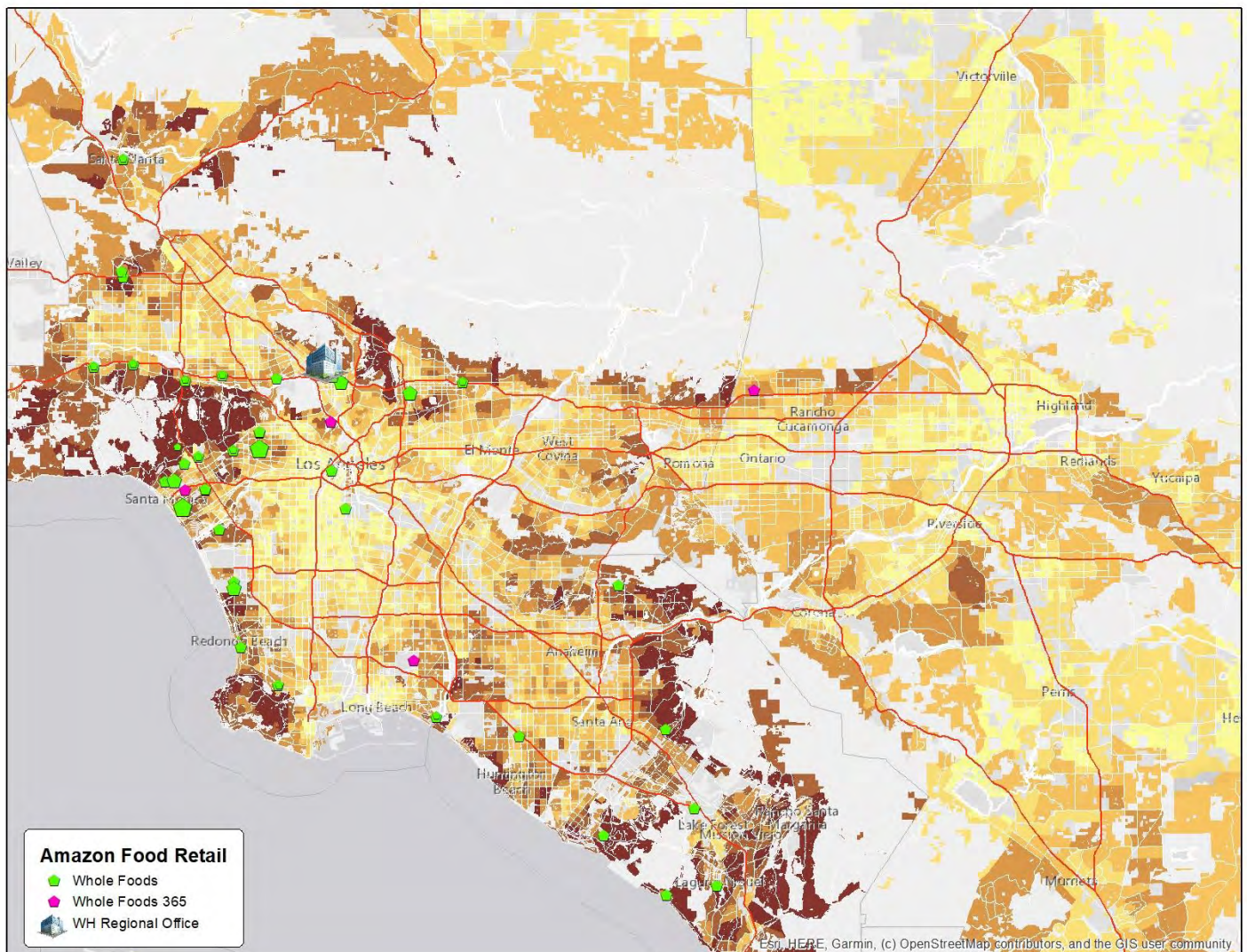

Source: Derived from U.S. Census Bureau American Community Survey 2013-2017 household income data and corporate data reported by Whole Foods.

four counties overlaid on shading of tracts showing average household purchases from Amazon.

Whole Foods employs an average of 188 workers at each store giving it an estimated 17,100 workers in the four-county region.¹⁵ The regional headquarters is located in Glendale, California. Each store has average annual sales of \$32 million, giving Whole Foods total annual estimated sales of over \$2.9 billion in the four-county region.¹⁶

Summary

Amazon has the following presence in the four-county study region:

- Estimated \$7.2 billion in e-commerce sales, representing 5.3 percent of Amazon's total annual e-commerce sales.
- Estimated average e-commerce sales of \$1,330 per household.
- Amazon's e-commerce sales are concentrated in affluent coastal and foothill areas.
- 91 Whole Foods stores, representing 18 percent of all Whole Foods stores.
- Estimated annual sales of \$3.2 billion and employment of 17,100 workers at 91 Whole Foods stores.
- Both e-commerce and Whole Foods sales are concentrated in high-income neighborhoods.



3. Logistics

Transporting Goods to Fulfillment Centers and then to Homes

Every day, ships, trucks, trains, and airplanes bring an estimated 21,500 diesel truck loads of merchandise to and from 21 Amazon warehouses in the four-county region in 2018.¹⁷ The warehouses are shown in *Figure 6*, with the size of circles representing the size of employment. An estimated total of 18,600 workers are currently employed at these Amazon warehouses.¹⁸

Most of the goods distributed through the warehouses arrive through ships that dock at the ports of Long Beach and Los Angeles, where the cargo is unloaded and trucked an average of 68 miles east to warehouses in the Inland Empire.

Goods in the fulfillment warehouses are trucked back to numerous local delivery hubs. Trailer trucks contracted by Amazon carry more than 2,000 packages at a time and bring orders from fulfillment centers to sortation

Figure 6: Amazon Warehouses in the Four-County Study Area

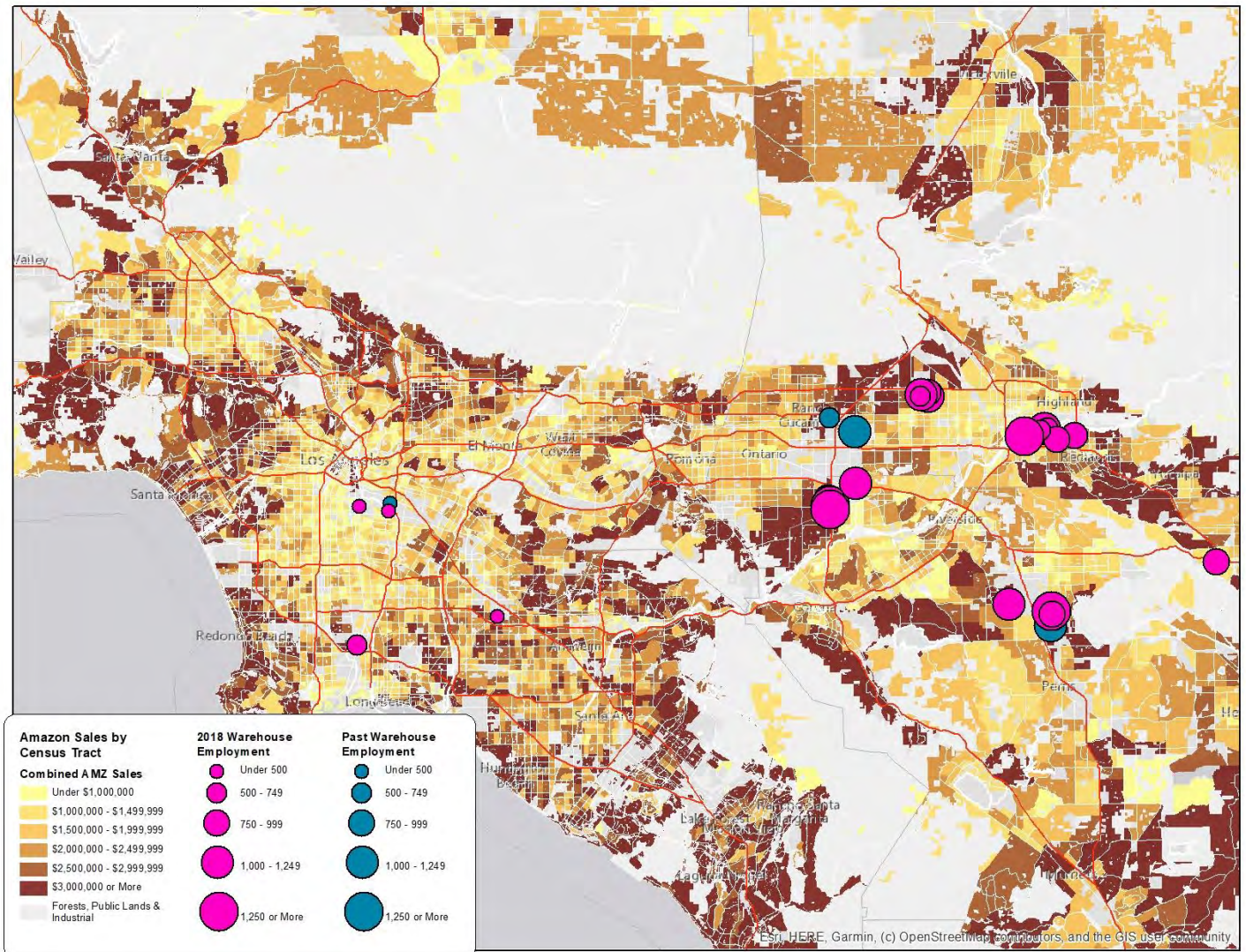

Source: Public records of Amazon facilities, using the ratio of square feet of warehouse space to employment from city environmental impact reports.

centers, where packages are distributed by location and the required delivery speed. From there they are shipped using multiple modes of transportation, ranging from Amazon trucks and planes to carriers such as UPS, FedEx, the U.S. Postal Service, and Amazon’s employed or subcontracted delivery drivers for last-mile delivery.¹⁹

Fulfillment Center Warehouses

Amazon has a total of 15.1 million square feet of warehouse space currently occupied in the four counties, and another 3.2 million square feet that it formerly occupied. Much of the formerly occupied space was leased while Amazon built its own facilities. Fifty percent of current warehouse space in the four counties is located in San Bernardino County, with another 44 percent in Riverside County. Amazon’s current and former warehouse space is broken out by city and county in *Figure 7*.

Four cities each currently have over two million square feet of Amazon warehouse facilities and account for over two-thirds of Amazon’s fulfillment center capacity in the four counties.

Amazon occupies 15.1 million square feet of warehouse space in the four-county region.

Figure 7: Square Feet of Amazon Fulfillment Center Warehouse Space

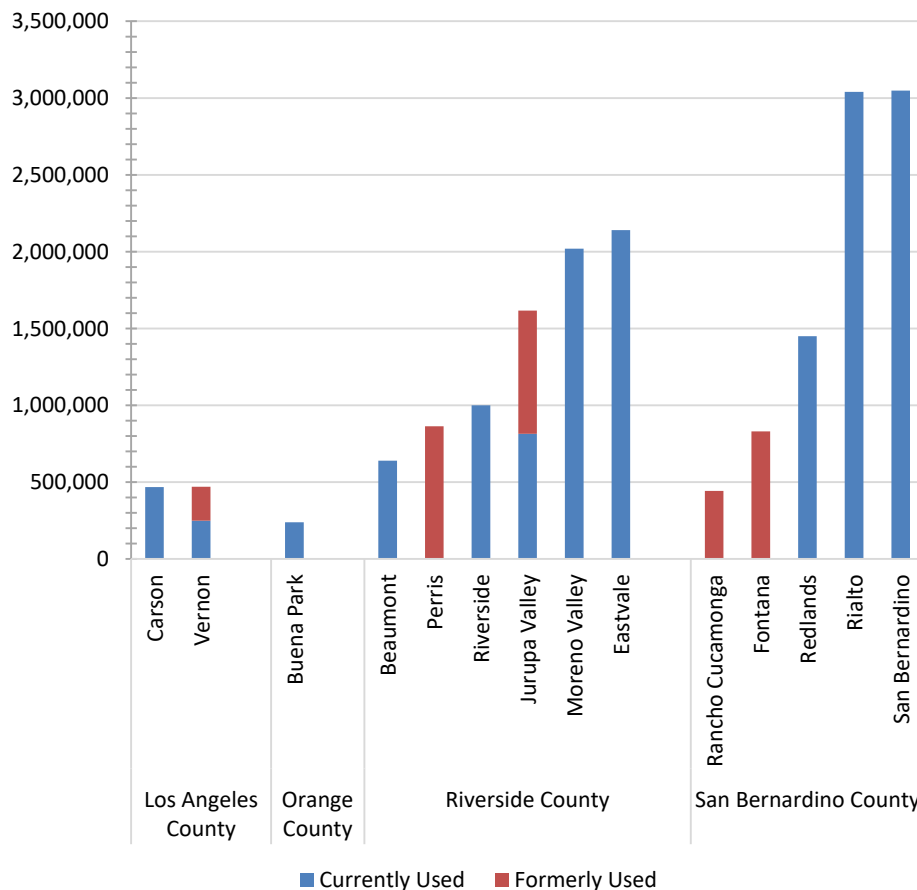

Source: Economic Roundtable analysis of public records.

- *City of San Bernardino* 3,048,900 square feet
- *City of Rialto* 3,040,448 square feet
- *City of Eastvale* 2,140,892 square feet
- *City of Moreno Valley* 2,019,300 square feet

Amazon has completely eliminated its presence in three cities, vacating 2.1 million square feet of warehouse space that it formerly occupied in Perris, Fontana and Rancho Cucamonga. Amazon doesn't appear to set down deep geographic roots.

At least 13 of Amazon's warehouses are held under the title of Golden State FC, LLC, a California subsidiary of Seattle-based Amazon that develops warehouses together with Hillwood, a commercial real estate investor and developer headquartered in Texas, and Clarion Partners, a real estate investment manager headquartered in New York.

The warehouses are large distribution centers. Five are larger than one-million square feet, or more than 23 acres under one roof.

The Inland Empire counties offer low-cost land, few regulatory hurdles for development, a blue collar labor force, and a highway infrastructure that connects sea and air ports to warehouse locations.

Transportation Impacts

Amazon's e-commerce transportation network creates multiple impacts and public costs while providing the much appreciated service of swiftly and reliably delivering goods we order over the internet to our homes.

Diesel Trucks

There is one estimated trip per day by a five-axle, 80,000 pound truck for every 702 square feet of space in a warehouse. When we annualize this to trips per year in 2018, based on the mileage from the ports of Long Beach and Los Angeles to each warehouse we get the following annual volume of trucking:

- 7,856,000 truck trips
- 388,269,000 miles traveled
- 15,530,762,000 ton-miles of truck and cargo travel

Nationally, there are funding shortfalls for the national Highway Trust Fund that are growing every year. This year, in 2019, the fund is projected to receive \$43.5 billion from fuel and vehicle taxes but to have highway maintenance costs of \$55.7 billion.²⁰ In densely traveled urban regions such as the Los Angeles Metropolitan Area, increases in truck traffic result in increases in unfunded infrastructure maintenance costs. Truck traffic to and from Amazon warehouses contributes to these unfunded public costs.

Amazon's diesel trucks hauled 15.5 billion ton-miles of cargo over roads in the four-county region in 2018.

The Congressional Budget Office has released estimates of the costs to the public that are not covered by taxes or fees based on ton-miles of truck travel.²¹ For example, an 80,000 pound truck traveling one mile represents 40 ton-miles. The estimated uncompensated public costs per ton-mile are:

- Pavement Damage \$0.0096
- Traffic Congestion \$0.0066
- Accident Risk \$0.0156
- PM & NOx Emissions \$0.0069
- CO₂ Emissions \$0.0022
- Noise (cost per mile) \$0.0304

Based on these cost factors, Amazon’s trucking operations in the four-county region in 2018 created an estimated \$642 million in uncompensated public costs, as shown in *Figure 9*. This included the following public costs:

- \$242 million in injuries, fatalities and property damage from accidents

Amazon’s trucking operations in 2018 created \$642 million in uncompensated public costs.

Figure 8: Uncompensated Public Costs from Amazon Warehouse Trucking in 2018

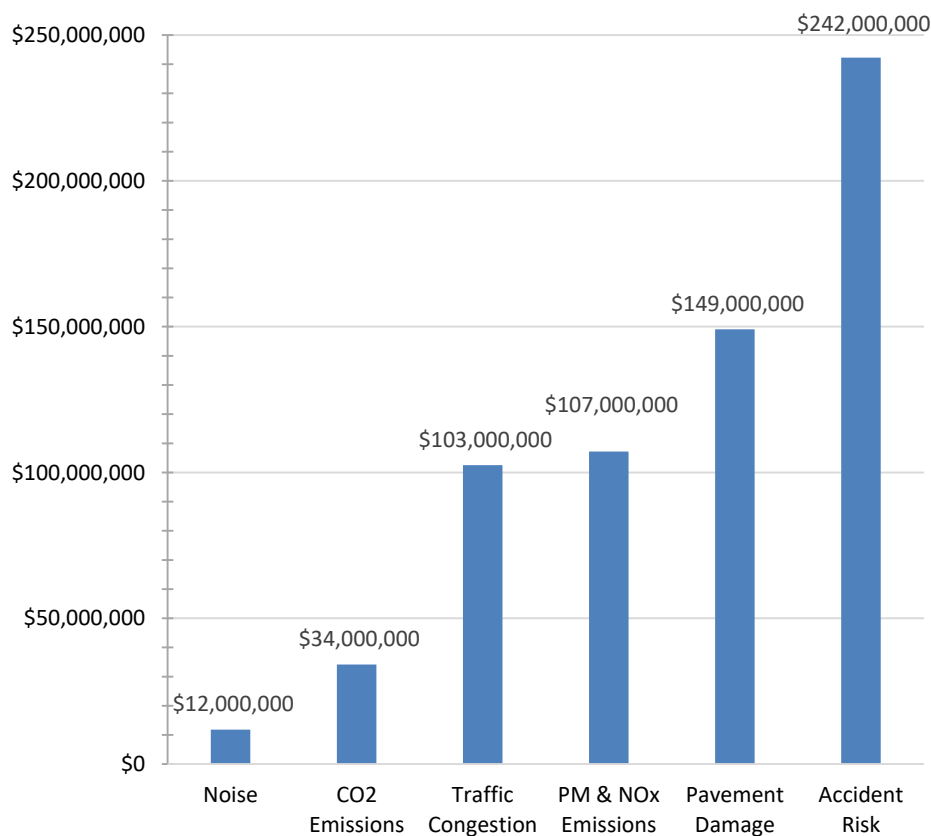

Source: Public records of Amazon facilities, ratio of square feet of warehouse space to number of truck trips and types of trucks from city EIR reports, miles of truck travel based on distance from the Port of Long Beach to each warehouse, and U.S. Congressional Budget estimates of uncompensated public costs per mile traveled.

- \$149 Million from wear and tear on roads and bridges
- \$107 million in harmful effects from exhaust emissions of particulate matter and nitrogen oxides
- \$103 million in delays caused by traffic congestion
- \$34 million in climate impacts from CO₂ greenhouse gas emissions
- \$12 million in loss of value caused by truck-related noise for adjacent properties.

Additional uncompensated infrastructure costs include the movement of massive quantities of concrete, rebar, structural steel as well as heavy equipment to build warehouses. There is anecdotal information that much of the structural steel for warehouses is transported by truck from Arkansas.

Community Impacts from Diesel Truck Emissions

Truck routes from ports to warehouses traverse low-income communities of color, adversely affecting air quality and health in those communities. The quantity of emissions caused by diesel truck emissions is proportionate to the size of each warehouse, as shown in *Figure 6*.

The combustion of diesel fuel in truck engines produces multiple types of emissions. *Carbon dioxide* emissions cause climate change and global warming. *Nitrogen oxide (NOx)* emissions in combination with other compounds in the air and sun light create ozone, which is the primary cause of smog.²² Smog contributes to health problems including asthma.²³ *Diesel particulate matter* is composed of carbon soot, most of which is less than one-seventieth the diameter of a human hair. These very small particles have serious health effects including cardiovascular and respiratory hospitalizations and premature death.²⁴

The primary trucking corridors from the ports of Long Beach and Los Angeles to warehouses in the Inland Empire are:

- *710 Freeway*, which impacts South Los Angeles and East Los Angeles
- *60 Freeway*, which impacts East Los Angeles, the San Gabriel Valley, Pomona, Ontario, Jurupa Valley, and Riverside
- *10 Freeway*, which impacts East Los Angeles, San Gabriel Valley, Pomona, Ontario, Fontana, Rialto, Colton, and San Bernardino.

Aircraft

Three airports in the Inland Empire deliver an average of 19 plane loads of cargo a day to the warehouses. Each Boeing 737 aircraft offloads enough

Figure 9: Amazon Warehouses in the Four-County Study Area

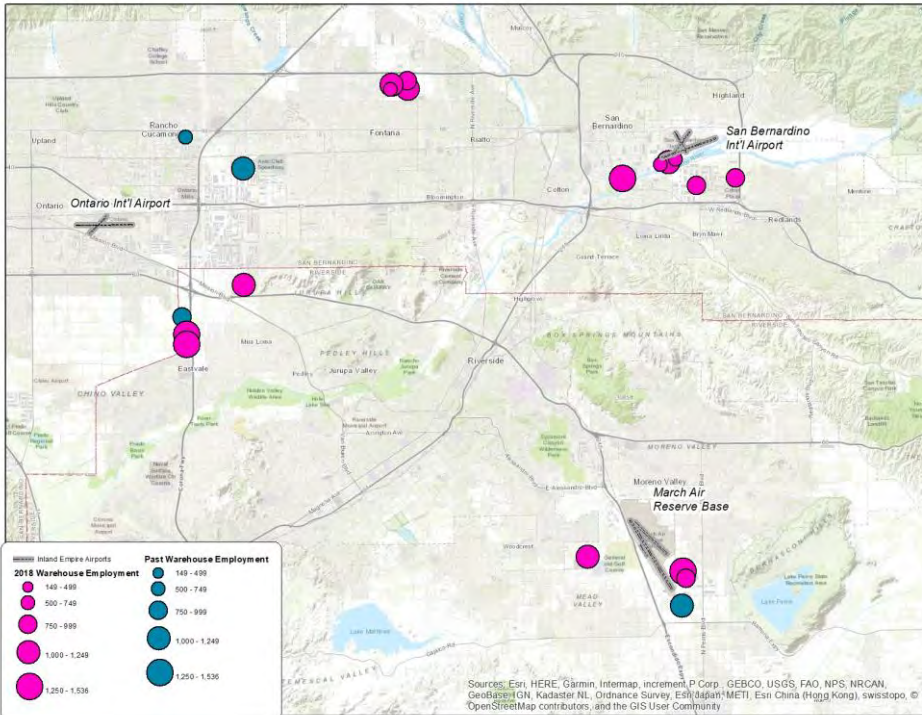

Source: Public records of Amazon facilities, using the ratio of square feet of warehouse space to employment from city environmental impact reports.

cargo to fill seven trucks, and is reloaded with cargo from another seven trucks. The planes travel an average of 2,182 miles on each flight, from and to cities such as Atlanta, Baltimore, Cincinnati, Honolulu, Orlando, San Antonio, and St. Louis. The three airports in the four-county region where these flights land and depart every day are:

- *March Airforce Base*: 3 planes landing and departing
- *San Bernardino International Airport*: 5 planes landing and departing
- *Ontario International Airport*: 11 planes landing and departing

The jet engine combustion from each mile flown by a Boeing 737 releases 53.3 pounds of carbon dioxide, a greenhouse gas. There were an estimated 11,800 Amazon cargo flights into and out of the three Inland Empire airports in 2018. With an average of 2,180 miles traveled per flight, Amazon’s flights into and out of the Los Angeles region released an estimated 620,000 metric tons of CO₂ into the atmosphere.

The social cost of carbon dioxide emissions in causing climate change and the resulting impacts on agricultural productivity, human health, property damages from increased flood risk, and the value of ecosystem services is estimated to be \$73 per metric ton.²⁵ The estimated annual social cost of the harm done by climate change caused by Amazon’s cargo plane flights into and out of the Inland Empire is \$45,315,000.

Amazon’s cargo flights in the Inland Empire cause \$45 million a year in climate change costs.

Logistics Employment

An estimated 46,000 workers in the four-county region were employed both by Amazon and its contractors in 2018 to move goods in the four-county region from inbound cargo carriers to warehouses, and then to customer's homes, as shown in *Figure 10*.²⁶ This includes 10,800 trailer truck drivers delivering cargo to and from warehouses, 18,600 workers at fulfillment center warehouses, and 16,600 delivery drivers bringing packages to our homes.²⁷

Last-Mile Delivery Services

Amazon delivered an estimated 692 million packages in the four-county region in 2018, which means roughly 2.2 million packages delivered every day.²⁸

Delivery service is provided by multiple competing package delivery companies. Amazon directly employs some delivery drivers, subcontracts with delivery groups that it helps create for additional capacity, and contracts with major courier companies and the U.S. Postal service for the majority of deliveries. As a result, there is over-capacity among delivery services and pressure for them to reduce wages to remain competitive.

Amazon has created over-capacity among delivery services and pressure for them to reduce wages to remain competitive.

Figure 10: Estimated Logistics Employment in the Four Counties in 2018

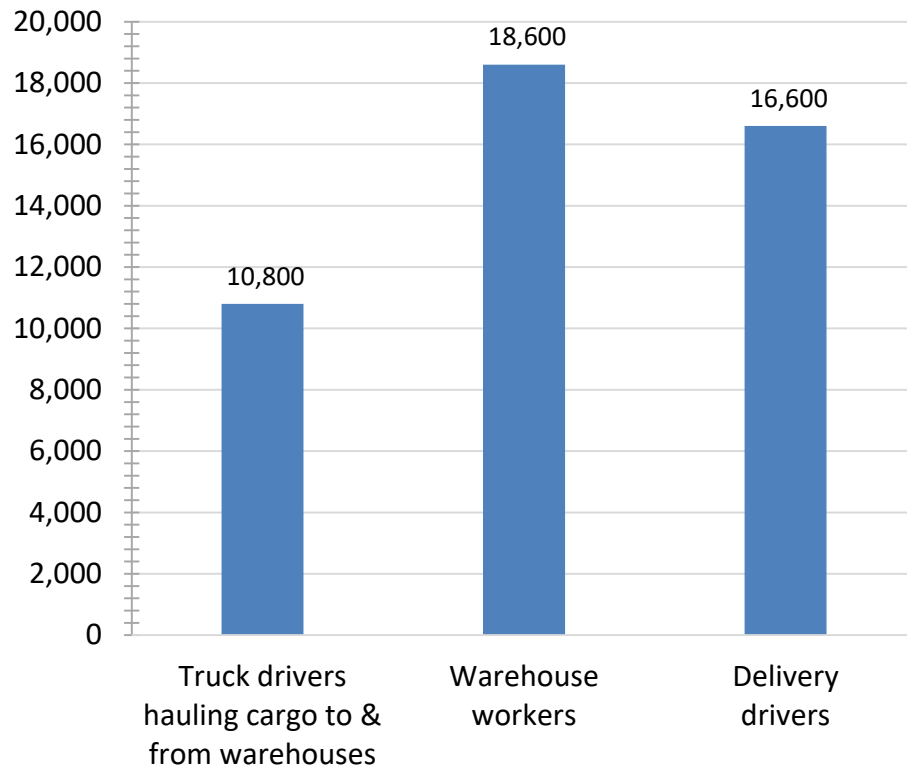

Source: Public records of Amazon facilities, ratio of square feet of warehouse space to number of truck trips, number of warehouse workers, number of packages delivered per driver, and number of packages delivered in the four-county region.

Figure 11: Daily Last-Mile Delivery of 2.2 Million Packages in the Four Counties in 2018

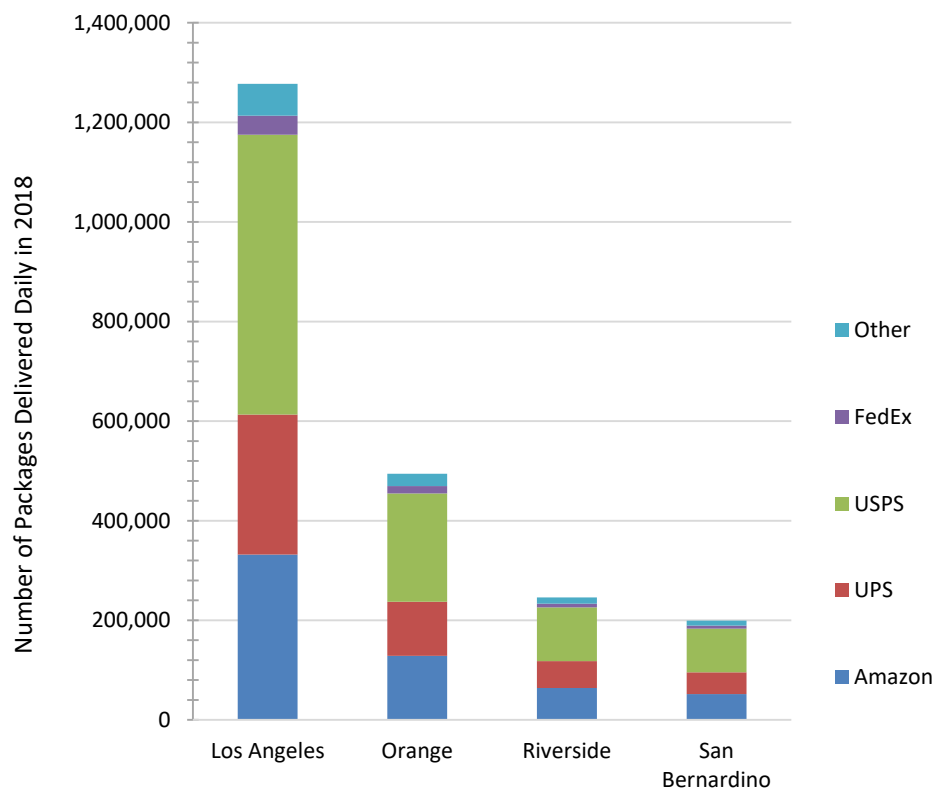

Source: Business Insider

The estimated breakout of delivery providers in each of the four counties, based on a national breakout, is shown in *Figure 11*. Based on this national breakout, Amazon and its in-house cadre of subcontractors delivered 26 percent of packages, United Parcel Service delivered 22 percent, the U.S. Postal Service 44 percent, FedEx (which has since ended its contract with Amazon) 3 percent, and other services 5 percent.²⁹

Last-Mile Delivery Cost

Shipping costs are reported to be a minimum of \$2.50 for a package, with the cost rising to \$3.50 to \$5.00 depending on the shipping distance and size of the package.³⁰ Estimates of the share of shipping costs accounted for by last-mile delivery range from a low of 28 percent³¹ to a high of 53 percent.³² Based on these estimates, Amazon’s cost for last-mile delivery of a package can range from a low of \$.70 to a high of \$2.65.

These last-mile costs are negligible for a \$150 electronic item or garment, but the average value of items sold by Amazon in the U.S. is reported to be \$9.15.³³ If these estimates are accurate, shipping costs exceed the margin of profit and create losses for the average package shipped by Amazon.

Amazon appears to be using rapid, low-cost delivery as a loss-leader to expand its retail market share. These losses are transferred in the form of low wages to delivery drivers who Amazon and its subcontractor employ.

These low-wage drivers, in turn, threaten the sustainable wages of union delivery workers employed by United Parcel Services and the U.S. Postal Service.

Summary

Amazon delivered an estimated 692 million e-commerce packages in the four-county region in 2018. This was accomplished through a logistics network made up of:

- 21 fulfillment center warehouses
- 15.1 million square feet of warehouse space that is concentrated in the cities of San Bernardino, Rialto, Eastvale, and Moreno Valley
- \$45,315,000.
- 10,800 heavy diesel truck drivers
- 18,600 warehouse workers
- 16,600 last-mile delivery drivers
- 7,856,000 truck trips during the year
- 388,269,000 miles traveled during the year
- 15,530,762,000 ton-miles of truck and cargo travel during the year
- The impacts from this logistics network include
 - \$647 million in uncompensated public costs in 2018 from truck travel generated by Amazon's warehouses
 - 11,800 cargo plane flights during the year
 - 620,000 metric tons of CO₂ discharged by cargo planes
 - \$45,315,000 in estimated annual social costs from the harm done by climate change caused by Amazon's cargo plane flights into and out of the Inland Empire.
- Amazon is using rapid, low-cost delivery as a loss-leader to expand its retail market share, with losses transferred to delivery drivers in the form of low wages.
- Congestion, accident and climate change social costs for last mile delivery logistics could not be estimated for the 692 million e-commerce packages delivered annually in the four-county region.



4. Warehouse Workers

Profile of Warehouse Workers

The typical line worker in an Amazon warehouse is a man who is 30 to 54 years old, Latino, with some college education, as shown in *Figure 12*. This worker profile is based on payroll records for workers employed on the physical footprints of Amazon warehouses in the four-county region.³⁴

This labor force is made up of employees in their most vigorous working years. Eighty-eight percent are 18 to 54 years old.

Half of workers, including managers, supervisors and professionals, earn from \$1,251 to \$3,333 a month, which is \$15,012 to \$39,996 a year. One-fifth of workers earn less than that.

Latinos make up over half of the warehouse labor force, followed by European Americans (34 percent), then by African Americans (7 percent), Asian Americans (4 percent), and other ethnicities (2 percent).

Figure 12: Profile of Amazon Warehouse Workers in 2017

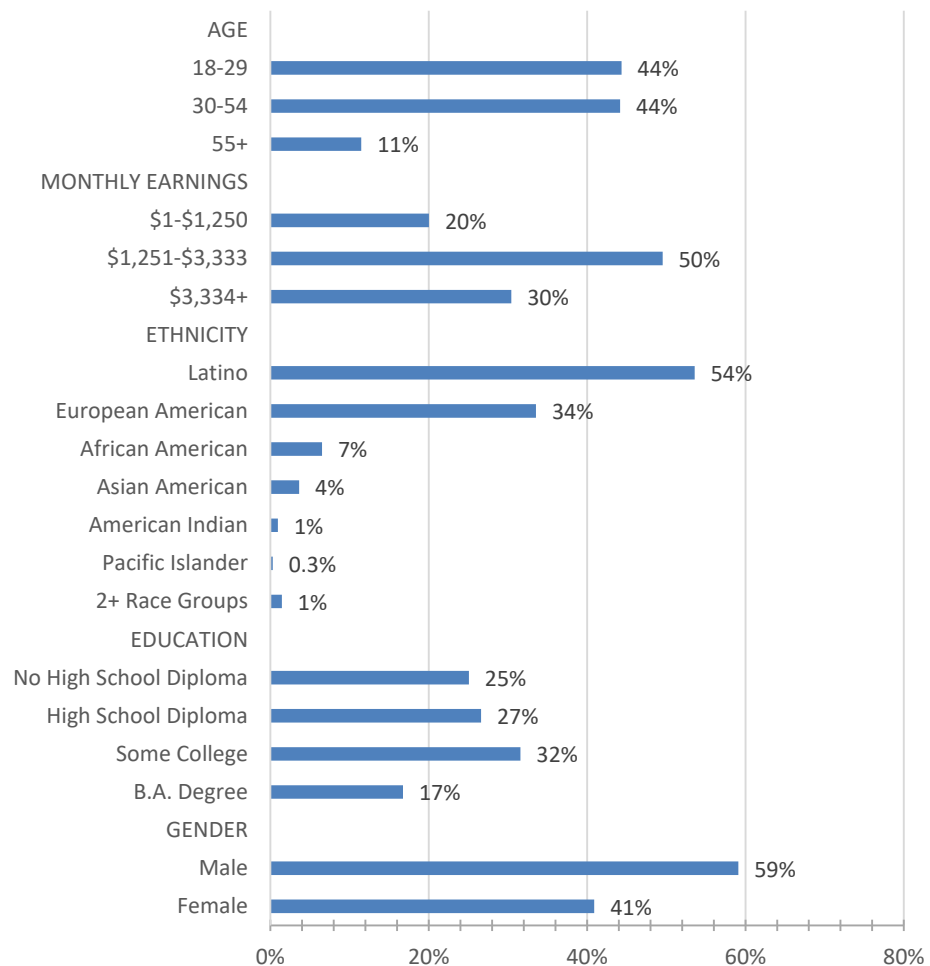

Source: U.S. Census Bureau, Longitudinal Employer-Household Dynamics data for workers employed within the footprint of Amazon warehouses in the four-county region in 2017.

Three--quarters of warehouse workers have at least a high school diploma and 49 percent have some level of college education.

Records of where Amazon warehouse workers live were matched with American Community Survey records for warehouse workers living in the same locations. This provides a broad range of information about workers' occupations, earnings, housing conditions, family structure, and reliance on public social safety net programs.³⁵

Eighty-seven percent of warehouse workers are in line occupations, which we define as occupations that are not managerial, supervisory or professional. The occupations of line workers are shown in *Figure 13*. The five largest occupations account for three-quarters of all line workers. These are: Laborers & Freight Movers (24 percent), Hand Packers (18 percent), Industrial Truck Operators (13 percent), Stock Clerks (10 percent), and Shipping and Receiving Clerks (8 percent).

Figure 13: 20 Largest Occupations of Line Workers in Amazon Warehouses, 2017

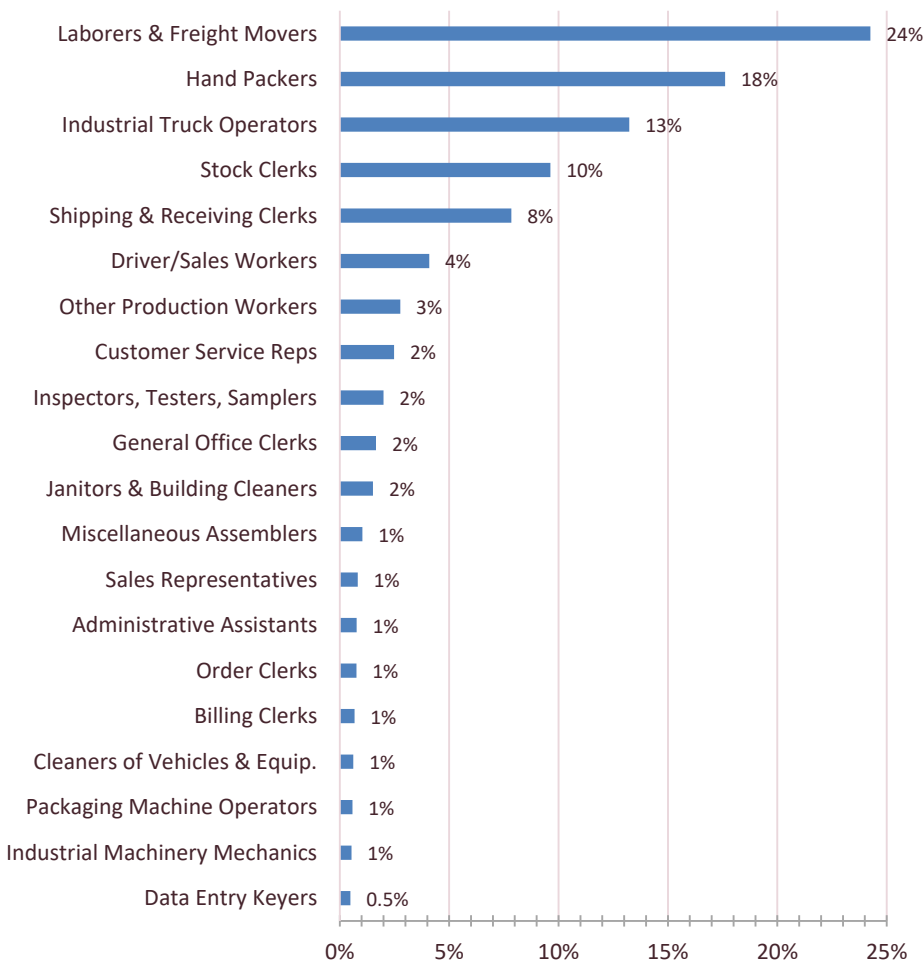

Source: U.S. Census Bureau, American Community Survey, Public Use Microdata Sample 2013-2017, for Los Angeles, Orange, Riverside, and San Bernardino counties. Occupational distribution is for line workers.

Where Workers Live

Proximity to lower-income neighborhoods facilitates Amazon's access to a job-hungry labor force.

The homes of warehouse workers are shown by the gray dots on the map in *Figure 14*, overlaid on census tract shading that shows neighborhood income, with warehouses marked by large circles. Most workers live in lower-income neighborhoods that are near warehouses.

One-third of Amazon warehouse workers are able to commute to work in 15 minutes or less. The average commuting time for warehouse workers is three minutes shorter than the overall average for the total regional labor force.

Proximity to lower-income neighborhoods facilitates Amazon's access to a job-hungry labor force. At the same time, the wages paid by Amazon perpetuate the economic struggles of these neighborhoods.

Figure 14: Residential Location of Amazon Warehouse Workers

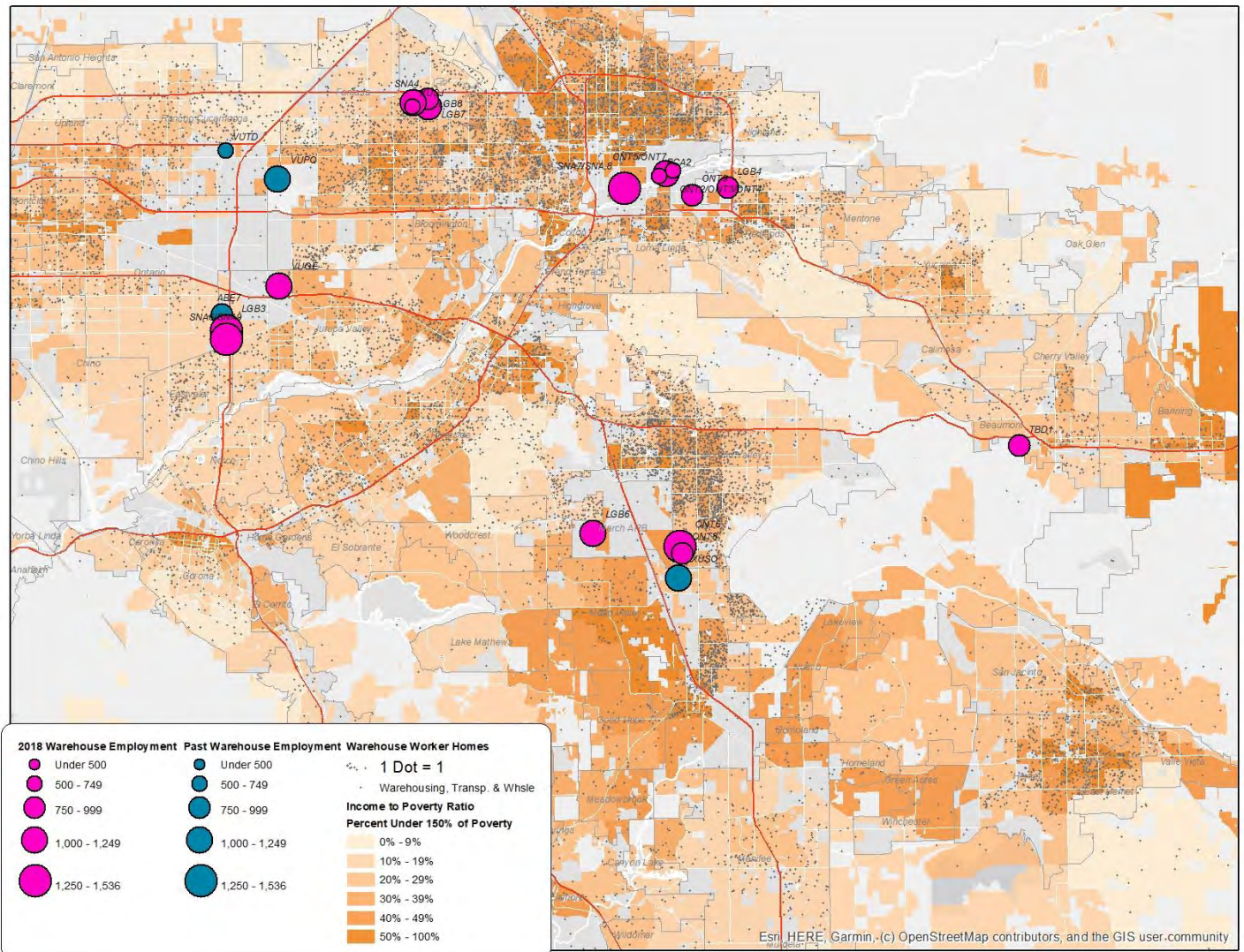

Source: U.S. Census Bureau, LEHD Origin-Destination Employment Statistics (LODES) records for workers employed at Amazon warehouses.

Figure 15: Cities Where Amazon Warehouse Workers Live

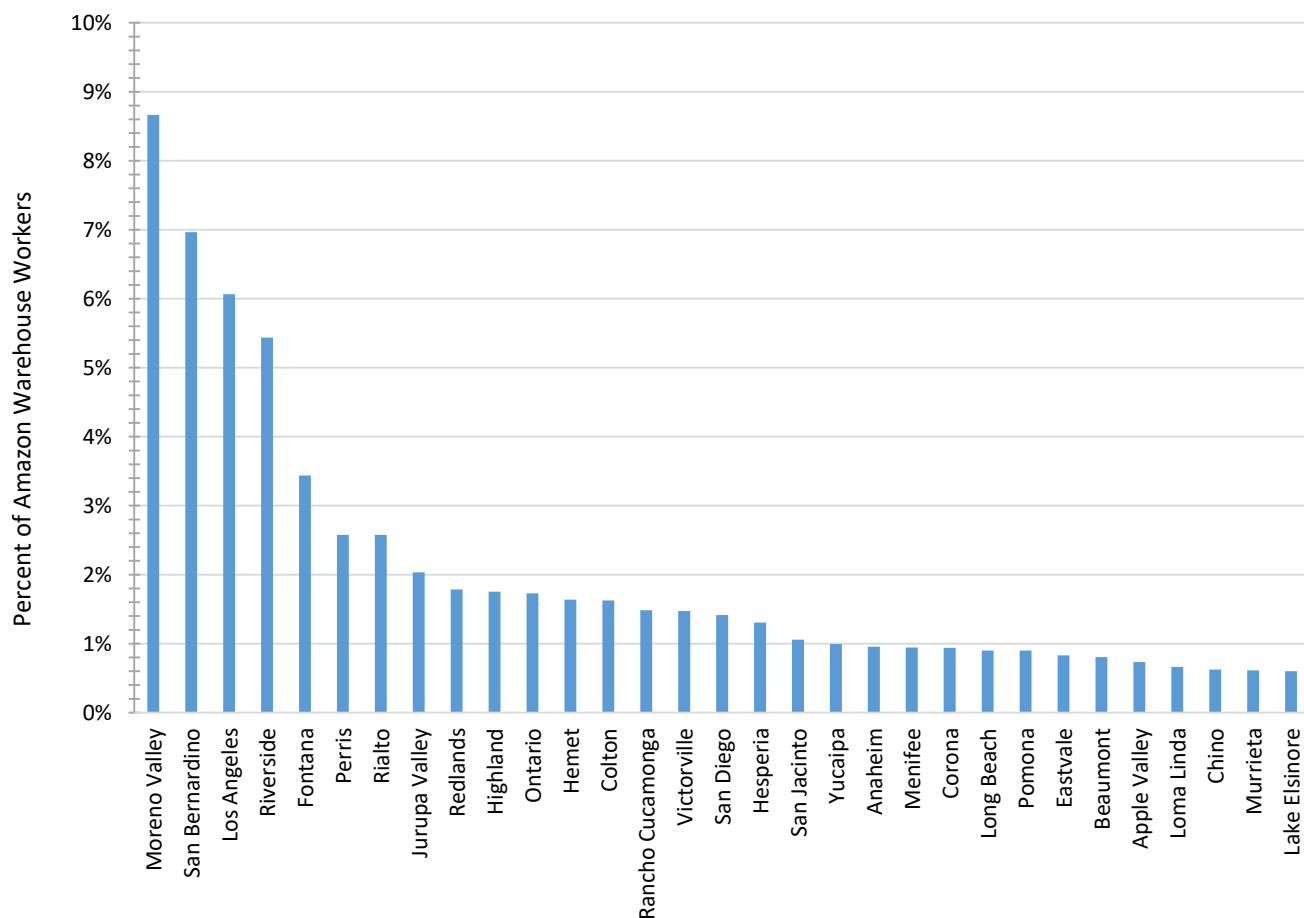

Source: U.S. Census Bureau, LEHD Origin-Destination Employment Statistics (LODES) records for workers employed at Amazon warehouses.

Most Amazon warehouse workers live in the western part of the Inland Empire, as shown by the breakout of cities where workers live in Figure 15.

Riverside County has concentrations of warehouse workers in the cities of Moreno Valley, Riverside, Perris, and Jurupa Valley.

San Bernardino County has concentrations of warehouse workers in the cities of San Bernardino, Fontana, Rialto, Redlands, Highland, Ontario, and Colton.

The geography of where customers live, where warehouses are located and where workers live reflects the economic polarization and structure of privilege in the four-county region. Amazon’s consumers are concentrated in affluent coastal and hillside communities. Warehouses and workers are concentrated in struggling working class communities. And public infrastructure bears the cost of trucking goods from ports to warehouses to consumers.

Earnings and Public Benefits

Most Amazon warehouse workers are helping to support large households that depend on their earnings. Only three percent of workers live alone. The typical household includes four people, and 49 percent of workers are part of households with five or more people, as shown in *Figure 16*.

Fifty-nine percent of line workers at Amazon warehouses are supporting children, and 22 percent have a person with a disability in their household.

The minimum annual earnings that each of two working adults need to receive in order to meet the basic living expenses of a family of four in 2018 ranged from \$37,108 in Riverside and San Bernardino counties to \$42,031 in Orange County. These living wage calculations are produced by the Massachusetts Institute of Technology for each U.S. county, and are shown below for the four-county region as well as in *Figure 17*.

- Los Angeles \$40,574
- Orange \$42,031
- Riverside \$37,108
- San Bernardino \$37,108

Most Amazon warehouse employees work full-time to meet the basic needs of their families, as shown in *Figure 18*. Sixty-one percent report that they work at least 40 hours a week, every week of the year (2,080

Most Amazon warehouse workers are supporting large households that depend on their earnings.

Figure 16: Household Size of Amazon Workers

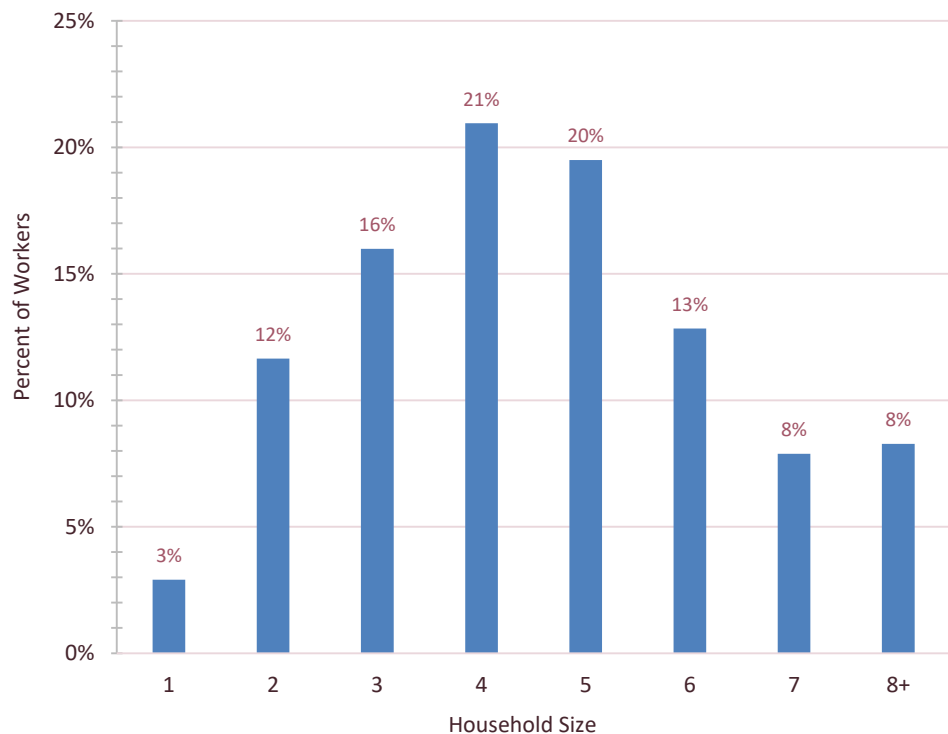

Source: U.S. Census Bureau, American Community Survey, Public Use Microdata Sample 2013-2017.

Figure 17: Basic Living Wage for a Family with 2 Adults, both Working, and 2 Children

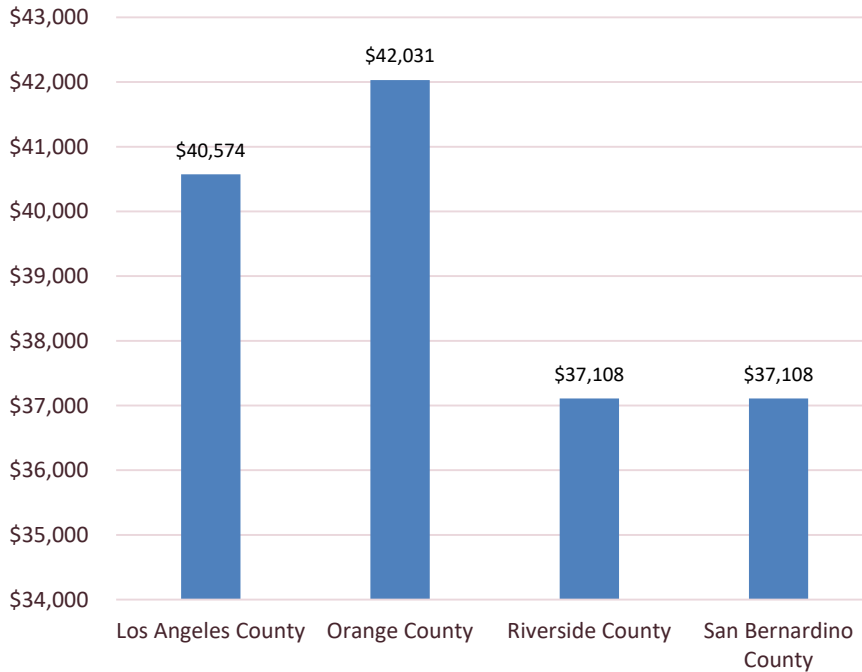

Source: Massachusetts Institute of Technology, Living Wage Calculator, for Los Angeles, Orange, Riverside, and San Bernardino counties: <https://livingwage.mit.edu/states/06/locations>

hours). The Affordable Care Act sets a lower threshold of 30 hour per week for full-time employment.³⁶ Using this lower threshold, an additional 10 percent of warehouse workers can be counted as full-time employees.

Figure 18: Number of Hours Worked in Year by Line Workers in Amazon Warehouses

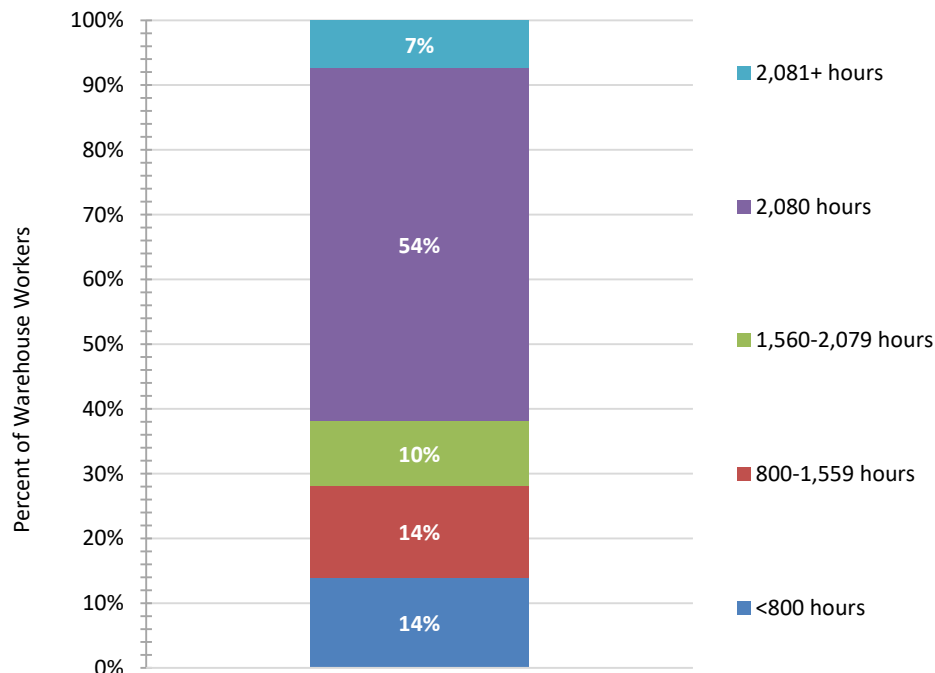

Source: U.S. Census Bureau, American Community Survey, Public Use Microdata Sample 2013-2017, for Los Angeles, Orange, Riverside, and San Bernardino counties. Data is for line workers.

Figure 19: Wage Distribution of Amazon Warehouse Workers in 2017\$

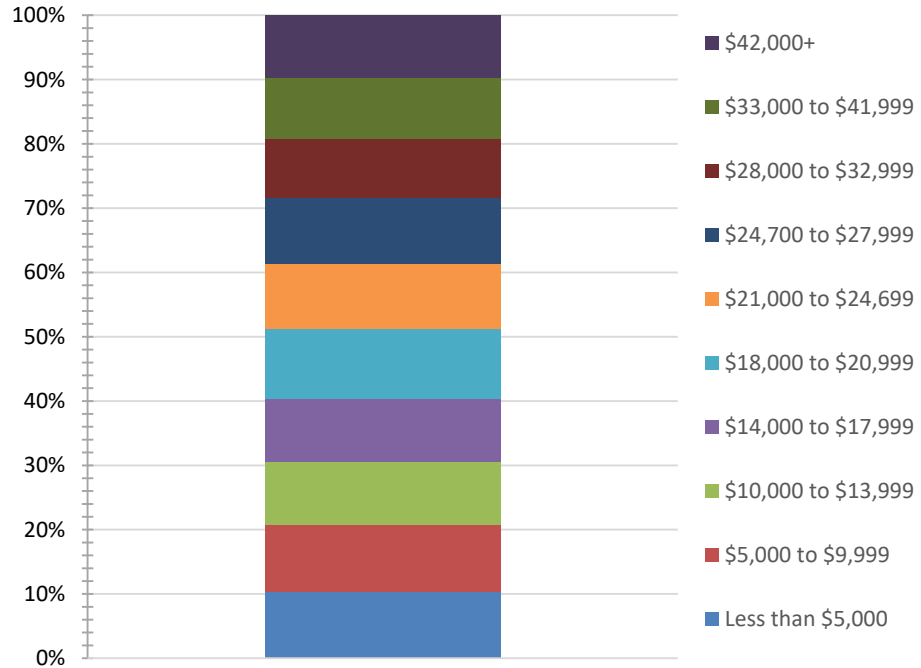

Source: U.S. Census Bureau, American Community Survey, Public Use Microdata Sample 2013-2017, for Los Angeles, Orange, Riverside, and San Bernardino counties. Data is for line workers, dollars adjusted to 2017.

In short, most workers are devoting all of their working energy to support their families through their Amazon warehouse jobs.

Figure 20: Median Annual Wages Based on Hours Worked

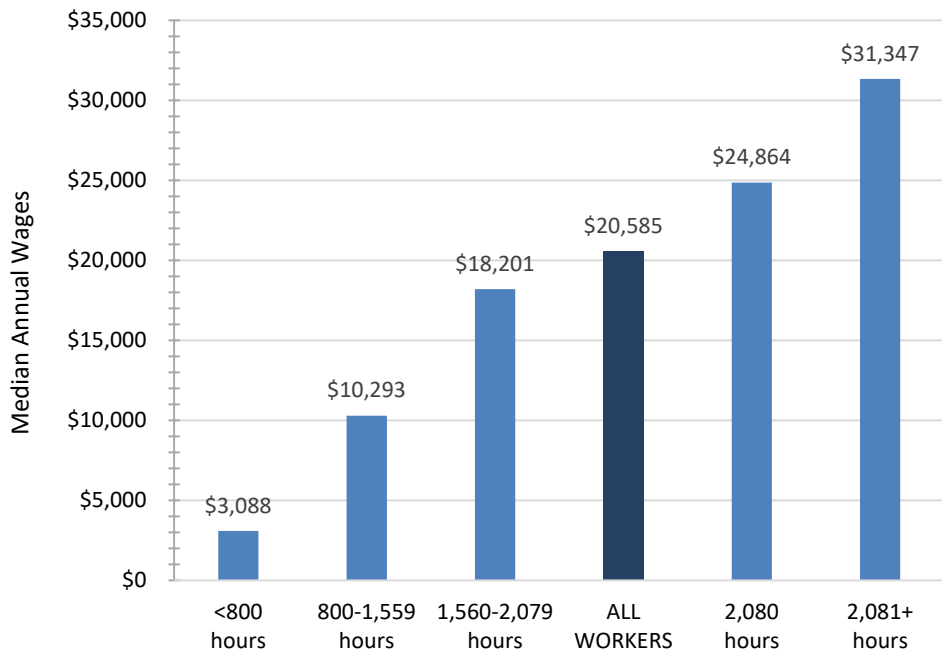

Source: U.S. Census Bureau, American Community Survey, Public Use Microdata Sample 2013-2017, for Los Angeles, Orange, Riverside, and San Bernardino counties. Data is for line workers, dollars adjusted to 2017.

Most Amazon warehouse workers earn less than a living wage. Eighty-six percent less than the basic living wage for Riverside and San Bernardino counties. Twenty-seven percent of workers live in Los Angeles and Orange counties and among those workers, 89 percent earn less than the living wage for those counties. The earnings distribution of warehouse workers is shown in *Figure 19*.

The typical (median) worker had total annual earnings in 2017 of \$20,585, which is slightly over half of the living wage for the four-county region.

Full-time work and even over-time work was not enough to bring workers up to a living wage, as shown in *Figure 20*. The median earnings of workers who were at the job for 40 hours a week, every week of the

The typical worker earned \$20,585 in 2017, which is only half of the living wage for the four-county region.

Figure 21: Median Earnings of Amazon Warehouse Workers in 20 Largest Occupations

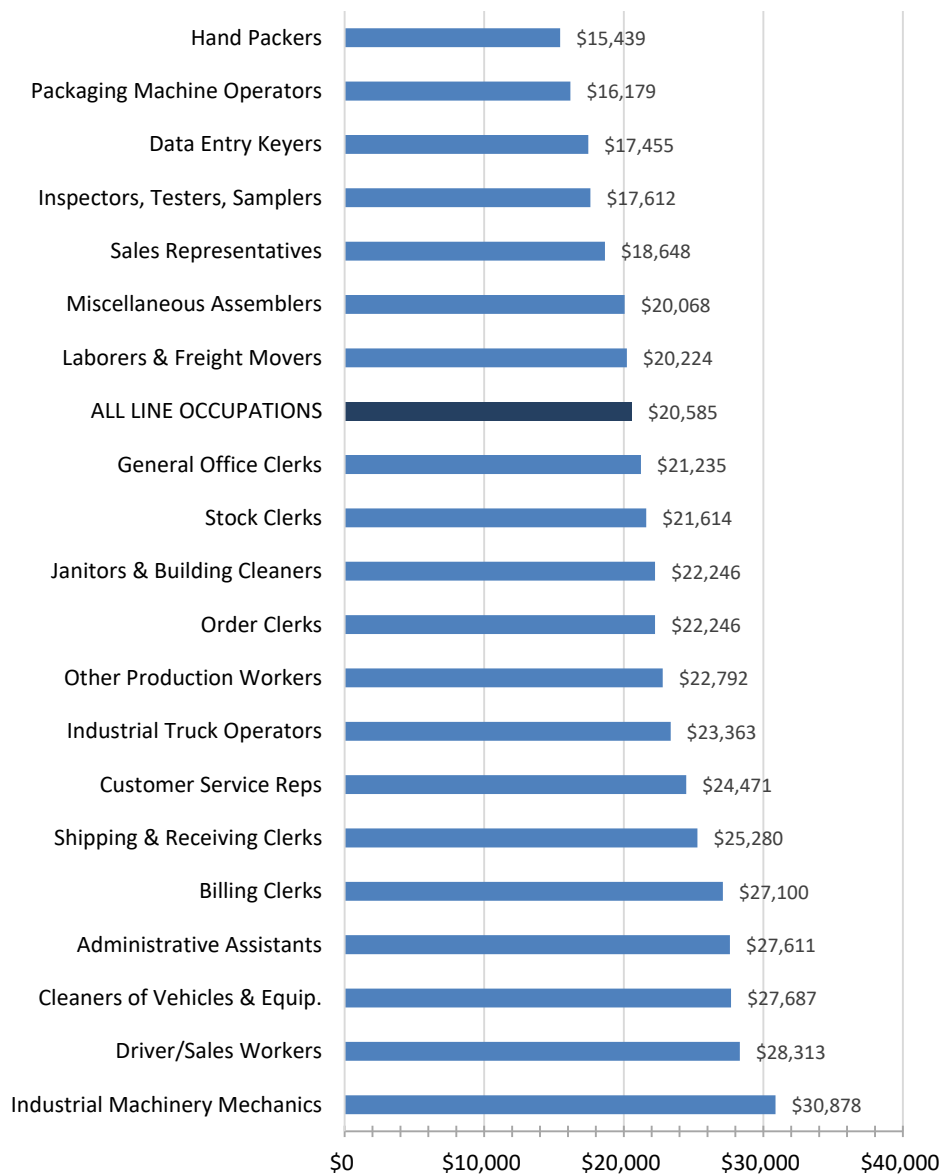

Source: U.S. Census Bureau, American Community Survey, Public Use Microdata Sample 2013-2017, for Los Angeles, Orange, Riverside, and San Bernardino counties. Earnings are for line workers in 2017 dollars.

year was \$24,864. Even the seven percent of workers who worked more than full time and received over-time pay had median earnings of only \$31,347, well short of a living wage in the Inland Empire.

Workers in the two largest occupations are paid less than the median wage, as shown in *Figure 21*. Hand packers typically earned \$15,439 a year and laborers and freight movers earned \$20,024. The highest paid workers are industrial machinery mechanics, who install and maintain warehouse machinery, and they typically earned \$30,878.

Amazon announced in 2018 that effective November 1 of that year, it was raising its minimum wage to \$15 an hour for all U.S. employees.³⁷ This policy change has not yet shown up in official data. For full-time workers who are employees of Amazon, it would raise the minimum annual wage to \$31,200. This was an important improvement for the lowest-paid workers, however, Amazon also announced that it was eliminating bonuses and stock awards for warehouse workers, so their net pay increase was less than what it appeared to be.³⁸

Poverty and the Wage Deficit

The most recent official data for Amazon warehouse workers shows that 14 percent are under the federal poverty threshold, a very low benchmark for

Figure 22: Household Income as Percent of Poverty Threshold

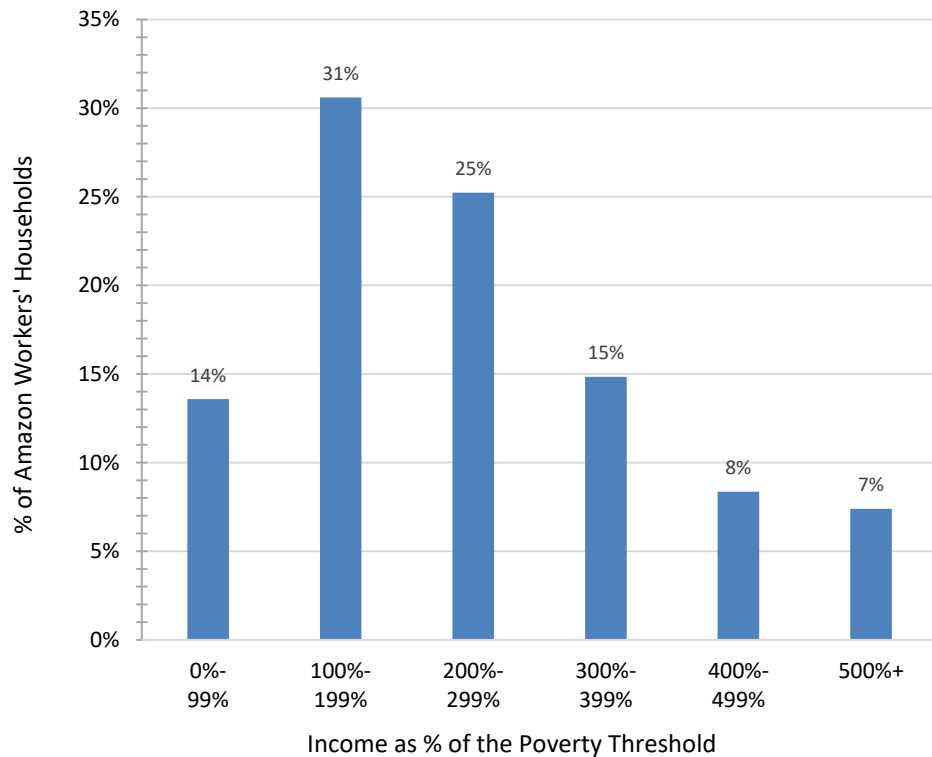

Source: U.S. Census Bureau, American Community Survey, Public Use Microdata Sample 2013-2017, for Los Angeles, Orange, Riverside, and San Bernardino counties. Data is for line workers.

high-cost regions such as Southern California, and another 31 percent are just above the poverty threshold. Altogether, 45 percent of warehouse workers are in poverty or near poverty, as shown in *Figure 22*.

As a consequence of their low incomes, 62 percent of Amazon warehouse workers and their families receive public assistance benefits, as shown in *Figure 23*. Workers and their families received different combinations of public assistance benefits:

- 58 percent receive their *health insurance through Medi-Cal*, which is the publicly subsidized health coverage for California residents with limited incomes.
- 20 percent receive *Food Stamps*, now called CalFresh, which assists low-income individuals and households in purchasing food.

Figure 23: Public Benefits Received by Households of Amazon Workers Based on Number of Hours Worked in Year

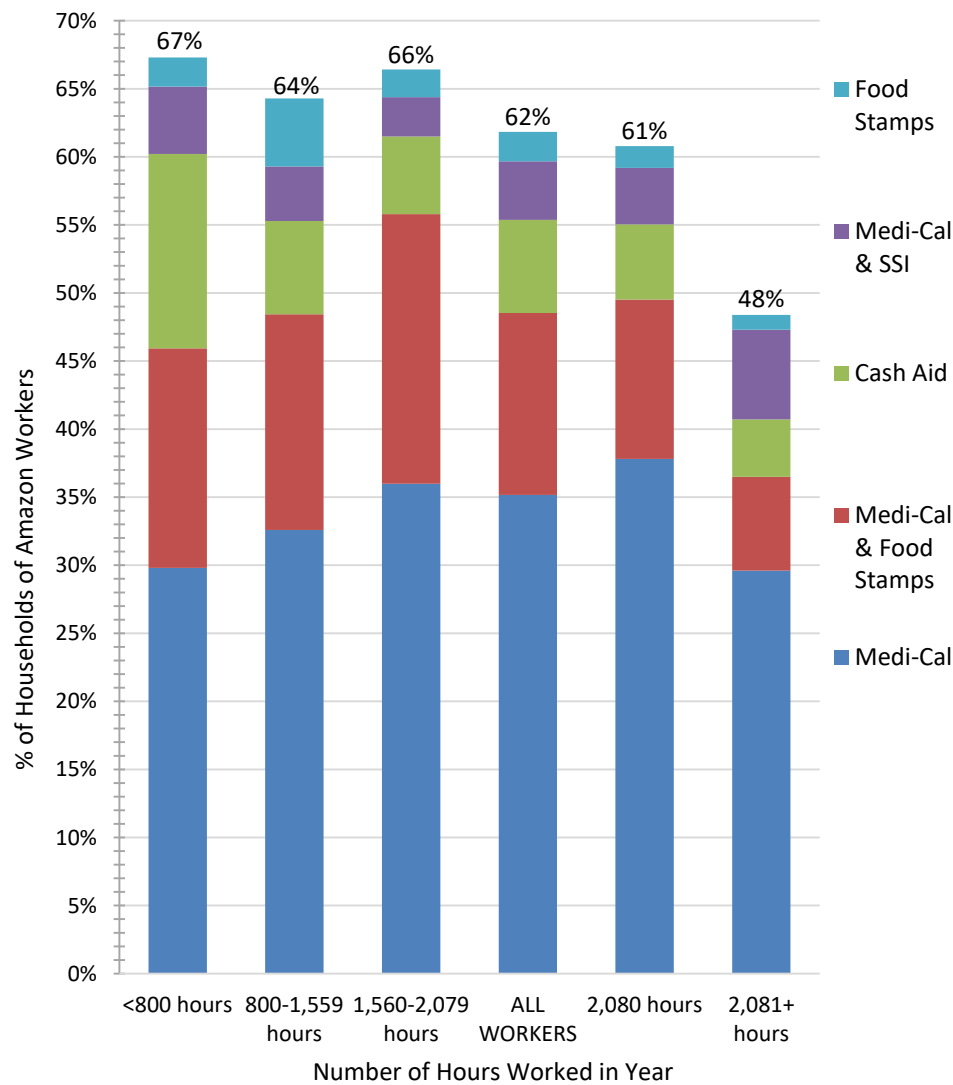

Source: U.S. Census Bureau, American Community Survey, Public Use Microdata Sample 2013-2017, for Los Angeles, Orange, Riverside, and San Bernardino counties. Public benefit rates are for line workers.

14% of workers are under the federal poverty threshold and another 31% percent are just above it.

- 7 percent receive *cash public assistance*.
- 5 percent have someone in their household who receives *Supplemental Security Income*, which pays monthly benefits to people with limited income who are disabled.

Sixty-one percent of workers who worked in warehouses 40 hours a week, every week of the year received public assistance benefits. Long, hard hours of work were not enough to free these workers from depending on the public social safety net for their survival. The fundamental problem was that their wages were too low to meet the basic needs of their families.

Figure 24: Average Annual Wages and Public Subsidies for Amazon Warehouse Workers

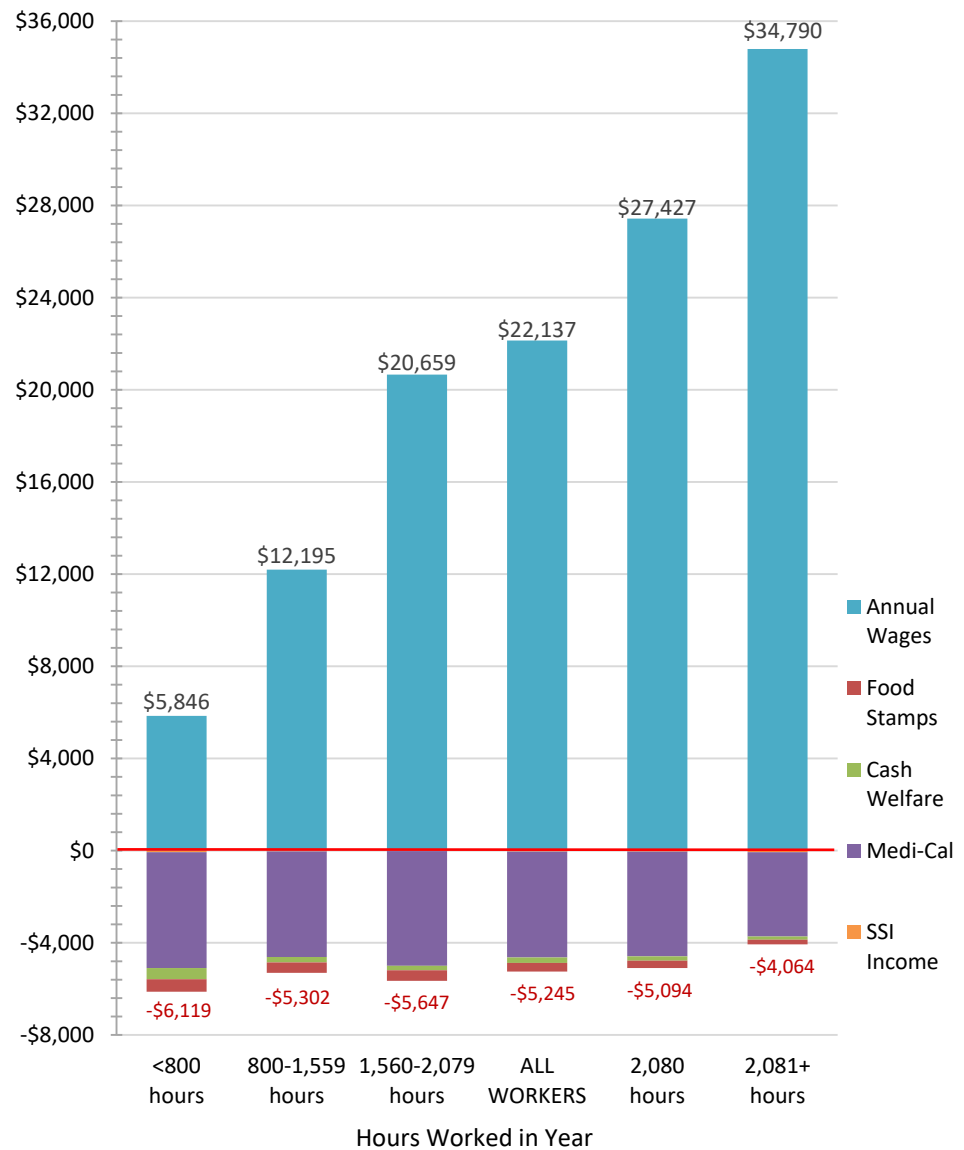

Source: U.S. Census Bureau, American Community Survey, Public Use Microdata Sample 2013-2017, for Los Angeles, Orange, Riverside, and San Bernardino counties. Data is for line workers in 2017 dollars. Earnings shown are averages rather than medians, as shown earlier. Benefit amounts are also averages.

Average wages and public benefit amounts for warehouse workers based on the number of hours they work are shown in *Figure 24*. Note that average wages are slightly higher than the *median wages* shown earlier.

On average, for every \$1 in wages paid by Amazon, warehouse workers receive \$0.24 in public benefits. The average annual amount of benefits per worker is \$5,245.

Public benefit amounts remain high even for full-time workers. Workers who were at the job 2,080 hours a year (40 hours a week, 52 weeks a year) received an average of \$5,094 in benefits to make up the deficit in the basic needs of their families that were not met by their wages.

The biggest component of public benefits is subsidized health insurance. The average annual amount of each benefit per worker family is as follows:

- Medi-Cal \$4,564
- Food stamps \$333
- Cash welfare \$237
- SSI \$48

For every \$1 in Amazon wages, warehouse workers receive 24¢ in public benefits, averaging \$5,245 a year per worker.

Wages of Other Logistics Workers

This report does not provide information about the earnings, reliance on public benefits or working conditions of logistics workers who drive diesel trucks to and from Amazon warehouses, delivery drivers who bring packages to customers' homes, or pilots who fly cargo planes. This work remains to be completed in a future study.

Housing Conditions

As a consequence of having low wages and insufficient incomes to afford adequate homes for their families, 57 percent of Amazon warehouse workers live in housing that is overcrowded and substandard, as shown in *Figure 25*. Many workers live in housing with multiple deficiencies.

- 41 percent are *doubled up* in housing with another family or an unrelated individual.
- 33 percent are *overcrowded*, which means more than one person per room or more than two people per bedroom.
- 21 percent live in *multigenerational* housing, which means that adult workers are living with their parents
- 1 percent report *homeless* conditions, including living in a vehicle, a homeless shelter, or a dwelling not approved for human habitation because it lacks plumbing or kitchen facilities.

The share of workers shown to be homeless in census data is likely to be the tip of the iceberg of more widespread homelessness. This is because the

Figure 25: Housing Conditions of Warehouse Workers

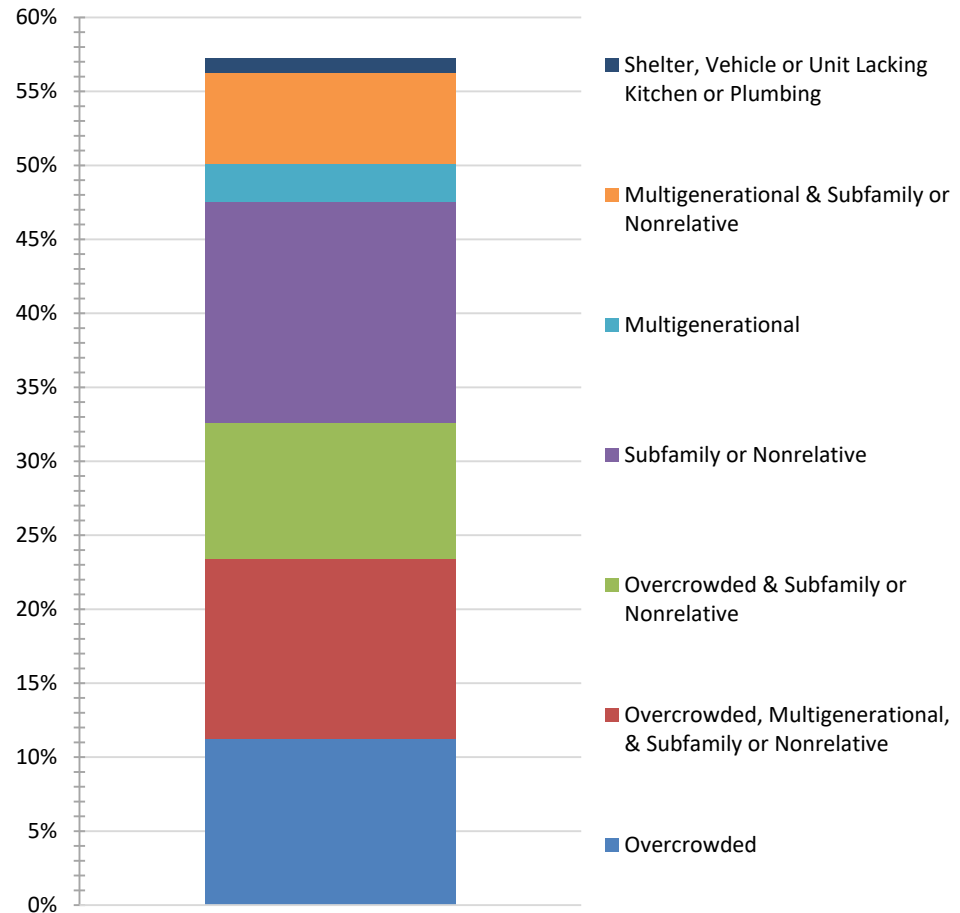

Source: U.S. Census Bureau, American Community Survey, Public Use Microdata Sample 2013-2017, Amazon warehouse workers in Los Angeles, Orange, Riverside, and San Bernardino counties

57% of Amazon warehouse workers live in housing that is overcrowded and substandard.

Census Bureau's American Community Survey only collects information from people who have an address in the Census Bureau's Master Address File of housing units and group quarters such as homeless shelters,³⁹ so homeless individuals are largely left out of the data unless they are in a shelter. The housing questions asked in the survey collect information about the address on the mailing label for the survey, making it unlikely that episodes of homelessness in the past year will be reported on the survey.

Summary

- The typical line worker in an Amazon warehouses is a man who is 30 to 54 years old, Latino, with some college education.
- Amazon warehouse workers are likely to live in a lower-income neighborhood near where they work, in the western part of the Inland Empire.

- The geography of where customers live, where warehouses are located and where workers live reflects the economic polarization and structure of privilege in the four-county region.
- Warehouses and workers are concentrated in struggling working class communities.
- Most Amazon warehouse workers are helping to support households that typically include four or more people.
- The basic living wage in Riverside and San Bernardino counties is \$37,108, and higher in Orange in Los Angeles counties.
- The median annual pay for an Amazon warehouse worker in 2017 was \$20,585, which is roughly half of a living wage for the region.
- 86 percent earn less than the basic living wage for Riverside and San Bernardino counties.
- 14 percent of warehouse workers are below the U.S. poverty threshold and 31 percent are just above the poverty threshold.
- 57 percent of Amazon warehouse workers live in overcrowded and substandard housing.
- Some warehouse workers are homeless, living in a vehicle, a homeless shelter, or a dwelling not approved for human habitation because it lacks plumbing or kitchen facilities.
- Public assistance benefits make up the wage deficit for 61 percent of Amazon warehouse workers and their families.
- For every \$1 in wages workers receive from Amazon, warehouse workers and their families receive an average of \$0.24 in public benefits to meet their essential needs.
- Workers and their families receive an average of \$5,094 in public benefits each year to make up the deficit for the basic needs that were not met by their wages.



5. Public Records Act Requests

Public Decisions about Amazon

The Economic Roundtable submitted California Public Records Act requests to 39 public jurisdictions in California, asking for all records related to Amazon and its subsidiaries. There were two reasons for the requests. First, to understand how public agencies make decisions that have accommodated and facilitated Amazon’s growth. Second, to identify public subsidies received by Amazon.

The public agencies that received these requests and a summary of their responses are shown in *Table 1*.

Amazon has facilities in every jurisdiction that received a records request. The records requests were sent with certificates of mailing. Subsequently, certified letters were sent to eleven nonrespondents, with follow-up emails. Responses were received from every jurisdiction except the *City of San Bernardino*, which has more Amazon warehouse space than any other city in the four-county region.

Absence of Public Records

Nineteen of the government jurisdictions said that they had no records related to Amazon. This includes the cities of *Jurupa Valley* and *Riverside* where Amazon has large warehouse facilities and *Culver City* where Amazon has a major movie production studio.

In a similar vein, the *County of San Bernardino* said that the records request was unduly burdensome because it was like looking for a “needle in a haystack,” even though the County led a campaign to be selected as the site for Amazon’s second headquarters.⁴⁰

The *City Clerk of San Bernardino*, Ms. Gigi Hanna, sent an email on June 13, 2019 stating, “The city did a thorough search for responsive records and there are no records.” Then, 23 minutes later, she sent a second email stating, “Gigi Hanna would like to recall the message.” The *City of San Bernardino* has failed to provide any further information.

Eight cities provided copies of permit applications such as building permits and business license applications. These showed oversight of compliance with construction and licensing requirements rather than policy reviews.

Ten public agencies provided documents that reflect a policy review of Amazon’s impacts on the environment, the transportation infrastructure, and the economy. In every instance these policy reviews determined that Amazon’s activities were benign and provided net benefits to the public.

19 government jurisdictions with Amazon facilities said they had no records related to Amazon.

Table 1: Summary of Responses to Public Records Act Requests

Jurisdiction	Response
City of Anaheim	No relevant records
City of Beaumont	2004 EIR, development agreement, credit reimbursement
City of Buena Park	Building permits
City of Carson	No relevant records
City of Chino	Soil, hydrology and trip generation studies
City of Commerce	Building permits
City of Culver City	No relevant records
City of Eastvale	2014 EIR - benign findings, looks at construction, not
City of Fontana	2011 & 2018 EIRs found significant impacts, fee waivers
City of Hawthorne	No relevant records
City of Highland	No relevant records
City of Inglewood	No relevant records
City of Irvine	Building permits
City of Jurupa Valley	No relevant records
City of Long Beach	No relevant records
City of Los Angeles	No relevant records
City of Moreno Valley	2006 negative EIR declaration, building permits
City of Perris	No relevant records
City of Rancho Cucamonga	Building permit
City of Redlands	Building permit
City of Redondo Beach	Business license application and conditional use permit
City of Rialto	2016 EIR with significant impacts, land transfer agreements
City of Riverside	No relevant records
City of Rosemead	No relevant records
City of San Bernardino	Response pending
City of Santa Monica	Building permits
City of Vernon	Redevelopment agency records, building permits
City of Victorville	No relevant records
County of Orange	No relevant records
County of Riverside	No relevant records
County of San Bernardino	Unduly burdensome – looking for a “needle in haystack”
Port of Long Beach	No records – Amazon is does not directly lease port facilities
Port of Los Angeles	No relevant records
Los Angeles International	No relevant records
March Joint Powers Authority	2018 addendum to 2004 Mitigated Negative Environ.
Ontario International Airport	2018 EIR addendum, 2007 Statement of Overriding
San Bernardino Airport	No relevant records
State of California Film	Provided list of \$25 million in subsidies for Amazon’s movies
California GO-Biz	Provided list of \$2.8 million in building construction subsidies

Environmental Impact Reports

Seven jurisdictions provided copies of environmental impact reports (EIRs) for the construction of Amazon's warehouses. These reports represent the most comprehensive review of the impacts and desirability of Amazon's logistics operations. Highlights of these reports are summarized below.

The **City of Beaumont** approved an Addendum to the Rolling Hills Ranch Specific Plan Environmental Impact Report in 2004, authorizing development of Rolling Hills Industrial, LLC. This development included 3,000,000 square feet of warehouse space. The EIR addendum concluded that the development would “not involve new significant environmental effects or a substantial increase in the severity of previously identified significant effects.”

The **City of Eastvale** approved an EIR for the Goodman Commerce Center in 2014 with 3,100,000 square feet of warehouse space. The law firm of Johnson & Sedlack filed a letter stating, “The EIR fails to adequately evaluate project impacts to/from agriculture, aesthetics, air quality, health risks, biology, noise, and cumulative impacts The project is located in an area with some of the worst air quality and health risk impacts in the nation. Additional mitigation for air quality and traffic must be adopted.” Extensive documentation of the adverse effects the project on air quality was submitted by the California Air Resources Board and the South Coast Air Quality Management District. The city council determined that although the project would have “significant and unavoidable” impacts, there were “overriding considerations,” described by the project developer as “thousands of badly needed jobs.”⁴¹

The **City of Fontana** approved an EIR for the Southwest Industrial Park with 22,387,358 square feet of warehouse space in 2011 and an EIR for the Southwest Fontana Logistics Center with 1,628,936 square feet of warehouse space in 2018. In the 2011 EIR the city determined that the project would help achieve goals for promoting orderly and compatible growth, increasing the daytime employment population, and fostering economic development. The EIR found significant but unavoidable impacts on air quality and traffic. In the 2018 EIR the city found that the Southwest Fontana Logistics Center would have a significant impact on the environment but that there were overriding considerations for approving the project. Those considerations were that “the project would generate between 1,500 and 2,000 jobs” and “help keep Fontana moving forward in a positive manner.”⁴²

The **City of Moreno Valley** approved a Mitigated Negative Environmental Declaration in 2006 for development of 2,057,400 square feet of warehouse space. The city found that “although the proposed project could have a significant effect on the environment, there will not be a significant effect in this case because revisions in the project have been made by or agreed to by the project proponent.” The environmental impacts included conflicting with the regional air quality plan, violating air quality standards, and adversely impacting the natural habitat.

The **City of Rialto** approved an EIR for the Renaissance Project with 4,000,000 square feet of warehouse space in 2016. The EIR found that the project “would result in the following cumulatively considerable impacts: Air quality, traffic noise, traffic (freeway congestion) and climate change.” However, Rialto determined that the project “meets community desires and balances the environmental protection goals with the need for housing, infrastructure, and economic vitality.”

The **March Joint Powers Authority** acted in 2018 to approve an Addendum to the 2004 Initial Study/Mitigated Negative Declaration, to reuse an existing, largely dormant aviation facility, March Air Reserve Base, for air cargo operations. A negative declaration was approved on the basis that the logistics activities that would resume on the air field were on a smaller scale than what had been authorized by a negative declaration in 2004. The new logistics operations entail 1,890 vehicle trips a day rather than the 2,520 trips previously approved, and 10 daily flights instead of 20.

The **Ontario International Airport** determined in 2018 that no new environmental review was needed for a project to construct a cargo facility on a 51-acre site and part of a taxiway on an adjacent, 19-acre site. This would support up to 79 flights a day. This conclusion was based on a 2007 EIR that supported a similar scope of logistics activities, identified significant air quality impacts, but concluded that this development was needed because, “The proposed Project could help foster growth in the Ontario area through the creation of jobs and by providing an international air cargo facility that may entice other businesses (such as off-Airport freight forwarders) to open offices in Ontario or move to the area.”

These seven EIRs represent the highest level of local policy analysis regarding Amazon’s impacts. Nineteen other jurisdictions said they had no records of any kind related to Amazon and another eight jurisdictions had only permit applications.

Yet the EIRs supported development of over 36 million square feet of warehouse space and up to 89 plane flights a day. No impacts on the environment, transportation infrastructure or human well-being were identified that warranted stopping a project. Often job creation was identified as the reason for proceeding with a project.

The “overriding consideration” for ignoring environmental impacts is that Amazon’s warehouses will provide good jobs and strengthen the economy.

Financial Subsidies

Four types of public subsidies for Amazon were identified through the California Public Records Act requests:

- California Film Commission subsidies for movie production
- California Office of Business and Economic Development subsidies for facility construction
- City waivers of development fees
- City subsidies in transfers of public lands

The first three types of subsidies are discussed in this report. Documents about sale of public lands are still being reviewed and are not discussed. This work remains to be completed in a future study.

California Film Commission

The California Film Commission has given \$25,028,000 to Amazon to subsidize production of six movies:

- Beautiful Boy \$4,000,000
- Don't Worry, He Won't Get Far On Foot \$1,091,000
- Good Girls Revolt, The 1 \$5,222,000
- Marlowe \$3,789,000
- Sneaky Pete 3 \$9,204,000
- Untitled Noah Baumbach \$1,722,000

This movie production has taken place in Culver City and Santa Monica, and is now being consolidated in Culver City.

Amazon received \$25 million in state subsidies for movie production.

California Office of Business and Economic Development

The California Office of Business and Economic Development has given \$2,775,000 to Amazon to subsidize construction of two buildings.

- \$1,575,000 for a warehouse in Moreno Valley. In announcing this subsidy the Governor's Office of Business and Economic Development said, "*With tens of thousands of employees across the state, Amazon is a major driver of both state and local economies. We are thrilled that Amazon has decided to continue to expand its operations in California.*"⁴³
- \$1,200,000 for an office building in Irvine where Amazon has software and professional teams working on Alexa, Appstore, Amazon Web Services, Lumberyard Games, and high performance computing. Amazon says the office "*provides a welcoming environment, with stocked snacks, ping pong, video game stations, food trucks at lunch time, and weekly socials to meet other team members.*"⁴⁴

City Waivers of Development Fees

Two cities provided records of waivers of development fees that are normally required of construction projects to offset their impacts on public infrastructure and facilities. Both Beaumont and Fontana provided development agreements that show similar fee waivers. Fontana's agreement for the 1,630,000 square foot Southwest Fontana Logistics Center stated, "The Project's Circulation Fee shall be assessed at the high-

cube warehouse development rate of \$1.755/bldg. square foot, which is 50% of the industrial/warehouse’s \$3.509/bldg. square foot rate.”⁴⁵

Similarly, the City of Beaumont reduced its Transportation Uniform Mitigation Fee (TUMF) for the 2,643,646 square foot Rolling Hills Crossroads Logistics Center to \$1.77 a square foot.⁴⁶

A waiver of \$1.755 a square foot for a 1,000,000 square foot warehouse represents a subsidy of \$1,755,000. Based on these two development agreements and the competition among cities for warehouse development, this subsidy level is estimated to have provided for the construction all of Amazon’s warehouse space for a total fee waiver subsidy of \$30 million.

Cities waived an estimated \$30 million in traffic impact fees to encourage Amazon to build warehouses.

Total Subsidies

The estimated total state and local subsidies of \$57,943,230 for Amazon in the four-county region are shown in *Figure 26*.

Figure 26: State and Local Subsidies for Amazon

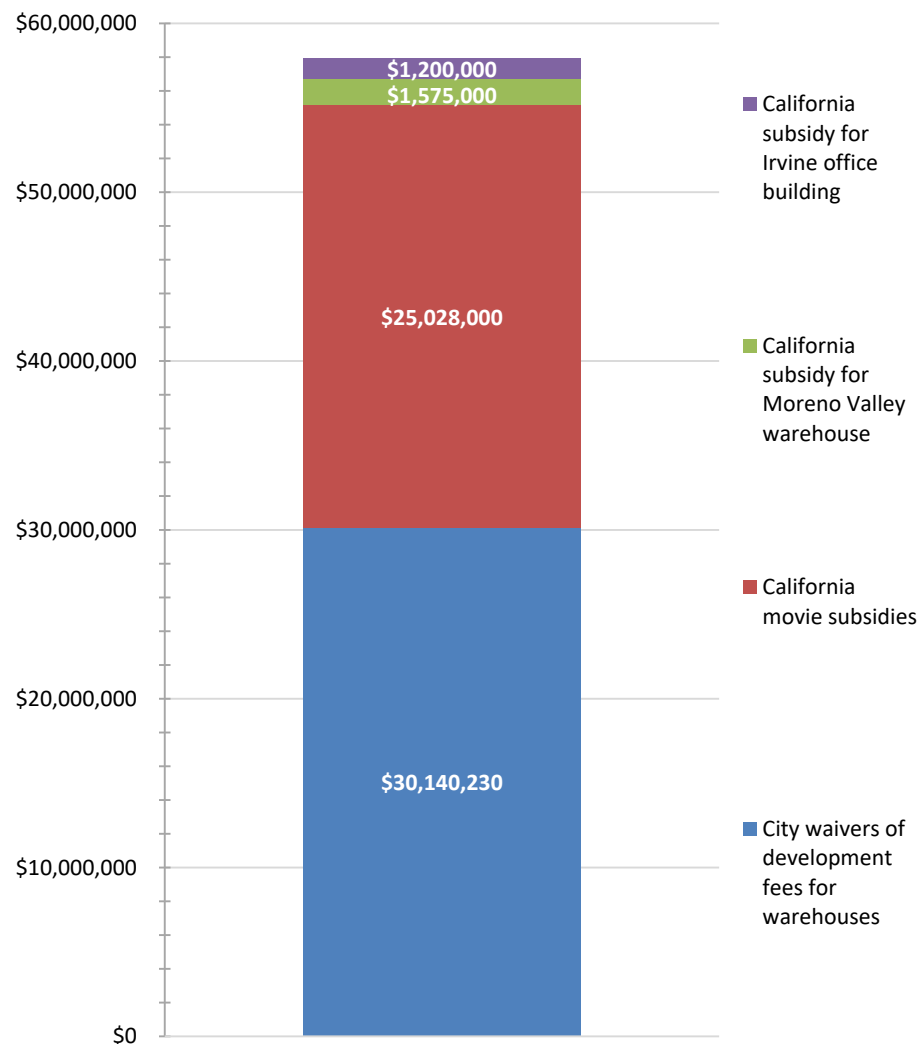

Source: Economic Roundtable estimates of Amazon subsidies.

Cities do not receive sales tax revenue from the sale of goods in local warehouses.

Absence of Tax Benefits

California returns \$0.01 from each \$1.00 in taxable sales to the city where the sale occurred. Some news organizations⁴⁷ and community stakeholders have assumed that this means there is a sales tax windfall for cities where Amazon fulfillment centers are located. *Figure 27* shows sales tax data for Inland Empire cities with Amazon fulfillment centers (blue columns) and neighboring cities without centers (green columns). California's overall average is by the orange column in the middle.

The chart shows the per capita amount sales tax revenue received by each city in 2018. The top part of the revenue column for each city is the amount of sales tax revenue received in the "other retail" category, which includes "non-store sales" by e-commerce retailers such as Amazon.

Cities with Amazon warehouses do not have more per capita revenue from "other retail" sales than neighboring cities, in fact they often have less revenue. This demonstrates that cities are *not* receiving tax revenue benefits from being the home for Amazon warehouses. It appears that a customer's address is identified as the point of sale rather than the fulfillment center that ships the item to the customer.

Figure 27: Per Capita Sales Tax Revenue Received by Inland Empire Cities in 2018

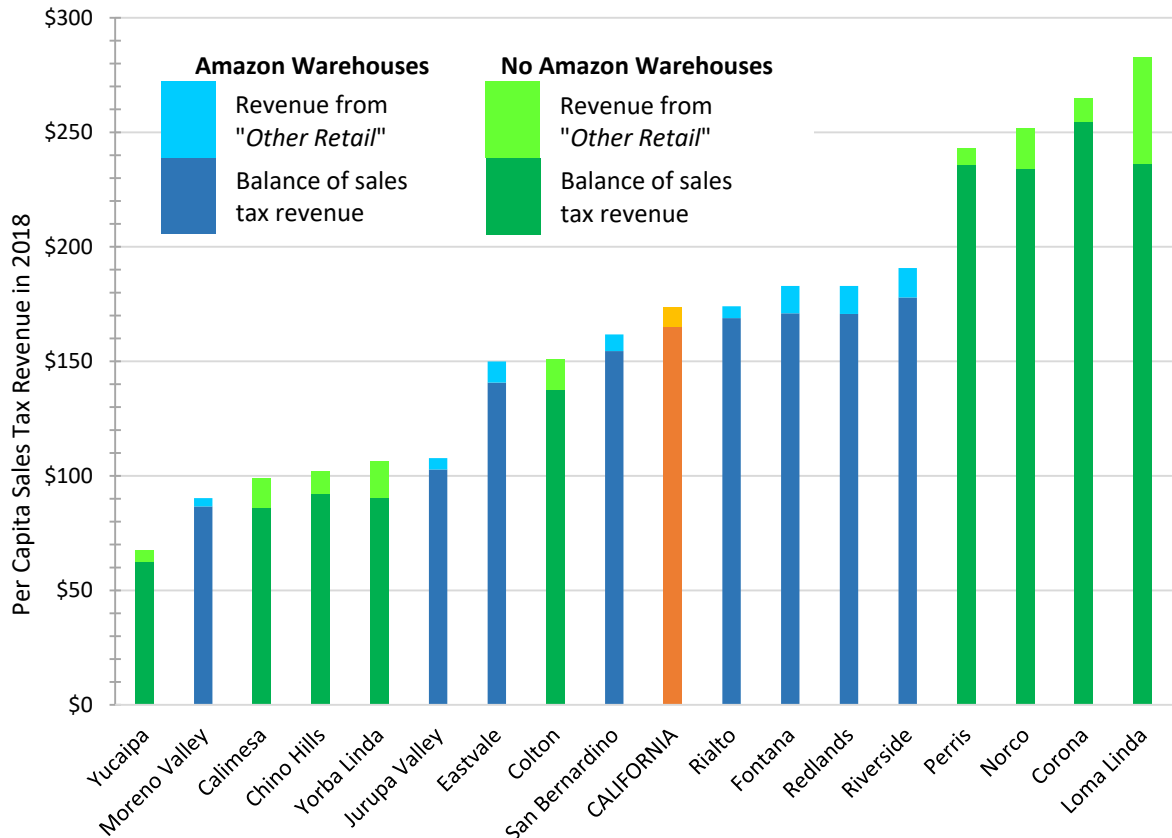

Source: California Board of Equalization, Payments to Cities and Counties from the 1% Local Sales and Use Tax, 2018-2019.

The only benefits that cities are receiving from Amazon's warehouses are from construction jobs and fees when warehouses are built and the employment of residents in warehouse jobs.

The “overriding consideration” put forward in EIRs is that Amazon's warehouses will provide good jobs and strengthen the economy. This expectation does not stand up to scrutiny. This report shows that Amazon's trucks cause extensive uncompensated damage to public roads and Amazon's warehouse jobs pay so little that workers can't afford adequate housing and rely on public assistance. The substandard housing conditions of Amazon's warehouse workers and their inability to afford food or healthcare for their families weaken the economies of cities.

Public tools for assessing and regulating Amazon's impacts are inadequate. The current policy review tools are used infrequently, look only at fragments of Amazon's local impacts, and show a strong pro-development bias. A new oversight structure is needed to assess the risk and impacts of Amazon's activities, and to establish regulatory standards that require the public balance sheet from Amazon's operations to pay its full costs to the public and to employees.

Summary

- There is very little public analysis of the costs and benefits from having Amazon facilities located in a community.
- Some jurisdictions have completed environmental impact reports that identify adverse environmental, infrastructure and human impacts, but these impacts are determined to be less important than the overriding consideration of increasing business activity and employment.
- Amazon has received \$57,943,230 from the State of California and cities. Movie production received \$25,028,000 in state subsidies, construction of a warehouse and an office building received \$2,775,000 in state subsidies, and cities have waived an estimated \$30,140,230 in transportation infrastructure impact fees.
- Cities where Amazon warehouses are located do not benefit from the sales tax collected on items shipped from those facilities.
- Cities' tools for assessing and regulating Amazon's impacts are inadequate.



Accelerated Data Lab Workshop

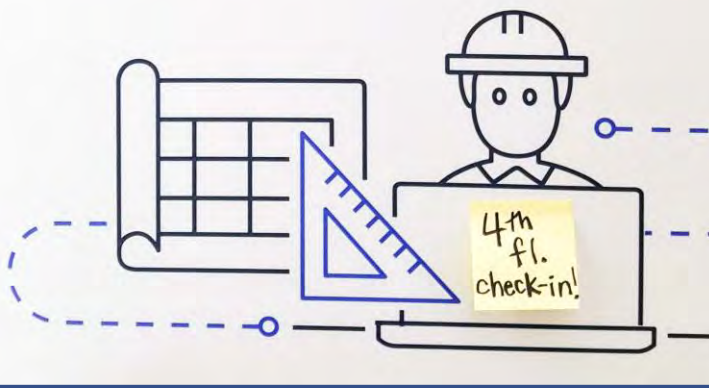

6. Amazon in Silicon Beach and Hollywood

Amazon Technology and Entertainment in SoCal

In the twenty-five years since Amazon.com Inc. began business as an online retailer, it has expanded and diversified into a multinational technology company active in a wide array of industries. Amazon’s cloud computing platform, *Amazon Web Services (AWS)*, started in 2002 as a side business supporting online retailing and has grown into the global industry leader.⁴⁸ This subsidiary hosts data and computer processing tools for private companies, schools, government agencies (including military), financial institutions, and non-profits.

Amazon.com founded *Amazon Studios*, a television and film production and distribution subsidiary with a streaming video orientation, in 2010.⁴⁹ It originally invited amateur screenwriters to submit film scripts to create content for Amazon’s “Prime Video” digital streaming service. Today Amazon Studios operates like a traditional film studio. This includes self-distributing feature length films through theaters starting in 2017, as well as creating original television series in-house.

Across the United States, Amazon.com has expanded its footprint by establishing “Tech Hubs” for its white collar, high-skilled workers outside of Seattle.⁵⁰ These are jobs in addition to its e-commerce distribution network of warehouses and delivery vehicles. Amazon’s 17 other tech hubs hired more than 17,500 staff by 2018, as it recruited the skilled workers needed to sustain growth and innovation in online retailing, software,

Los Angeles’ computer technology and entertainment workforce enable Amazon’s growth and expansion.

Table 2: Amazon Tech Hubs Employment and Specialties

Tech Hub City	Employment	Amazon.com Subsidiaries and Divisions
Seattle	145,750	Amazon HQ1
San Francisco	16,500	Amazon Devices; Amazon Web Services (AWS); Alexa
Washington, D.C.	6,875	AWS; Amazon Global Corporate, HQ2
New York City	4,950	Amazon Media Group; Fashion; Publishing
Los Angeles	3,575	Amazon Studios; Game Studios; Prime Video; IMDb
Boston	3,300	Alexa; Amazon Robotics; Audible
Vancouver, Canada	2,750	Alexa; AWS; Amazon Fulfillment Technology
Austin, Texas	2,338	Amazon Business; Amazon Fulfillment Technology
Toronto	1,650	Amazon Fulfillment Technology; Amazon Alexa; AWS
Dallas	1,375	AWS
Portland, Oregon	1,100	AWS; AWS Elemental
Phoenix	963	Amazon Business; Amazon Marketplace
Atlanta	756	Amazon Fulfillment Technology; AWS
Chicago	550	AWS; Amazon Media Group
Denver	550	Amazon Devices; AWS
Detroit	481	Amazon Marketplace
Minneapolis	413	Transportation Technology; AWS; Amazon Lockers
Pittsburgh	179	Amazon Translation Services and Products; Alexa
Total	194,054	

Sources: Weise, Elizabeth. 2018. “Amazon is no longer a Seattle company.” *USA Today*, August 13, 2018. Adjustments for undercounting and increased hiring based on Economic Roundtable analysis.

Figure 28: Amazon Workers by Industry Sector, Los Angeles, Seattle and New York

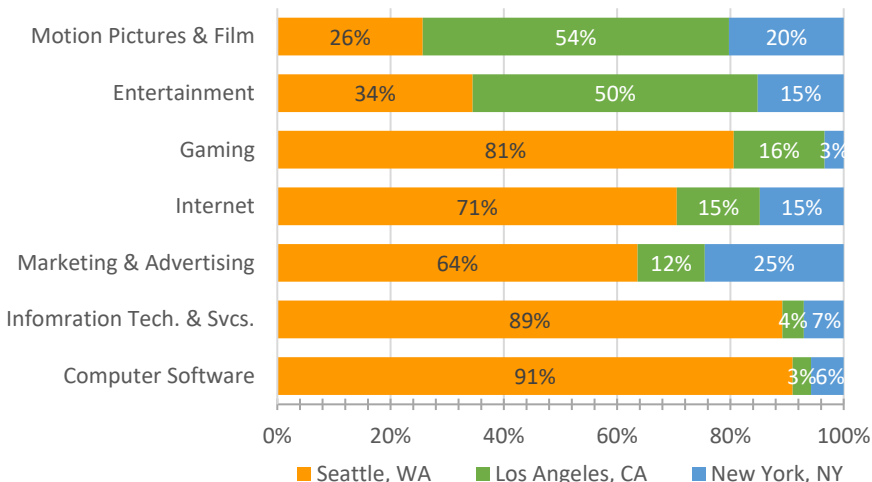

Sources: Economic Roundtable analysis of LinkedIn.com job profiles of Amazon employees in the Los Angeles, Seattle and New York regions, by LinkedIn industry sector; November 2019.

cloud computing, logistics, gaming, video, robotics, IoT (Internet of Things), news, and other businesses (Table 2).

The Los Angeles region ranks fifth among these hubs based upon employment, as Amazon has built its presence in Silicon Beach and Hollywood, with an estimated 3,575 Los Angeles region employees in its technology and entertainment sectors. Compared to the company’s headquarters in Seattle and its New York City hub, the Los Angeles region has its largest shares of employment in the motion pictures and film, entertainment, gaming and Internet job sectors, as shown in Figure 28.

Amazon.com opened these operations in Southern California due to the region’s established pools of entertainment and technology workers, taking advantage of the talent already present in “Silicon Beach,” as shown by the map in Figure 29. Amazon.com currently has most of its full-time, non-fulfillment workforce in Santa Monica (“Water Garden”), Culver City (“Studios” and “Steps”) and Irvine (“Pacifica”). The West Los Angeles staff include Amazon Studios staff, plus those working on video and advertising, and IMDb (Internet Movie Database) programming. Amazon staff at the Irvine office include those working on software and video games.

Economic Impacts of Amazon in Southern California

Being a multinational, multichannel, online retail and technology company, Amazon.com has economic impacts in industry sectors across the economy. When its warehousing operations, food retailing, technology and entertainment make new sales, these stimulate ‘upstream’ economic ripple effects. All of the ‘upstream’ goods and services that Amazon purchases in order to carry out its own varied business operations are ‘indirect’

Figure 29: Amazon Entertainment and Tech Sites in Los Angeles, Relative to High Skilled Workers

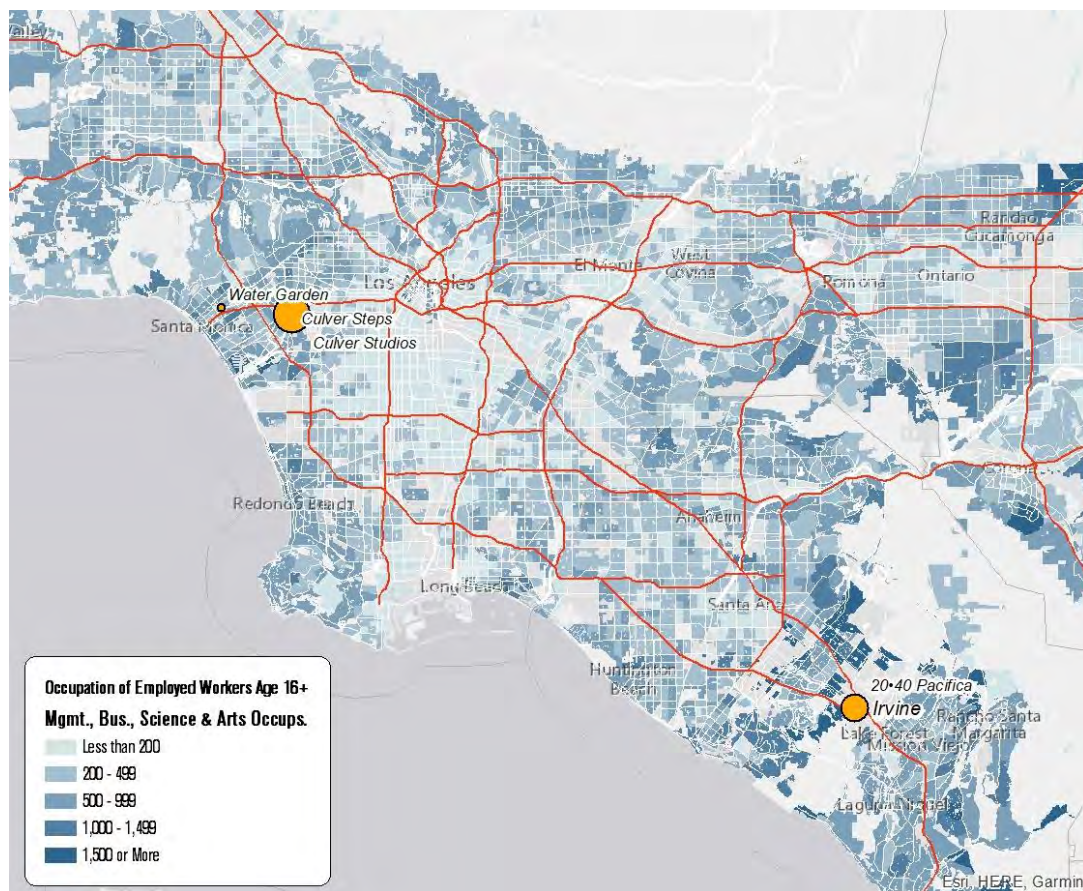

Source: U.S. Census Bureau 2017 5-Year American Community Survey occupational data, Economic Roundtable analysis.

economic impacts on its suppliers who have added economic activity because of their sales to Amazon.

We utilize an input-output model of the regional economy to estimate the local economic and job impacts of Amazon.com in three industry sectors, using IMPLAN software and regional accounts data. This model produces detailed estimates of Amazon’s economic impacts in the regional economy that result from different segments of its business (Figure 30).

The biggest upstream impacts of Amazon’s *warehousing* operations are felt in the real estate and equipment leasing industries (NAICIS 53). For every \$1 million dollars of Amazon’s own sales activity passing through its fulfillment centers, it spends \$114,000 on real estate and equipment leasing services in the region. The next three biggest upstream effects of its warehousing operations are:

- Just under \$52,000 in Amazon expenditures for outsourced warehousing, shipping and courier services in the area (NAICS 49)
- Over \$38,000 for local administrative support, waste management and remediation services businesses (NAICS 56)
- Over \$37,000 for local professional, scientific, and technical services (NAICS 54)

Building lease costs are Amazon’s largest upstream economic impact for its warehousing and grocery operations.

Figure 30: Upstream Economic Impacts of \$1 Million of Sales in Warehousing, Grocery Stores, and Motion Picture and Video Industries

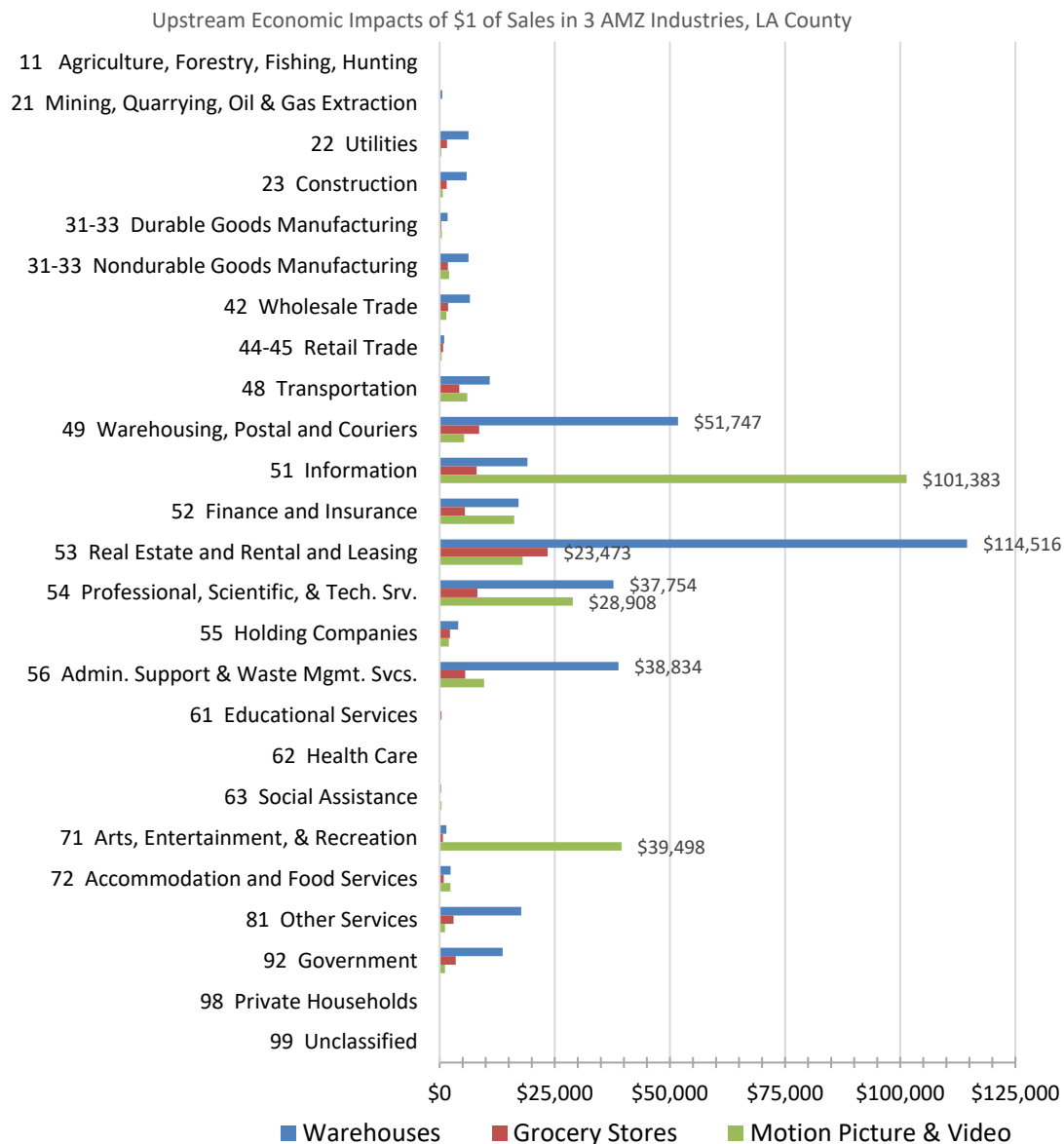

Sources: Economic Roundtable analysis; Minnesota IMPLAN Group, Inc., IMPLAN System 2016 data and 2019 software; Output (Sales) of three industry sectors given a \$1 million increase in activity in Los Angeles County, California.

Amazon’s grocery business, carried out through its subsidiaries *Whole Foods*, *Whole Foods 365*, *Amazon Fresh*, and *Amazon Go*, has smaller upstream economic impacts, though the industries affected are similar to warehousing. The grocery industry operates on very thin margins, but one fixed cost of business is the commercial leases paid to the owners of their brick-n-mortar grocery store properties. For every \$1 million dollars of Amazon’s own grocery sales in the study area, it spends an estimated \$23,473 on real estate and leasing services in the region (NACIS 53). The overall amount of indirect, upstream economic impacts in this sector is relatively low, and is a reflection of geographic ‘leakage,’ with much of Amazon’s grocery procurement expenditures going to farms and factories outside the region, out of state, and abroad.

Amazon's *entertainment* businesses include *Amazon Prime Video*, *Amazon Studios*, *IMDb*, *Audible* and other units. The largest share of upstream impacts from expenditures by these subsidiaries are to procure services from other companies in the Information sector (NACIS 51), with over \$101,000 in procurements from these companies for every \$1 million in sales by Amazon. These upstream service providers to Amazon.com may include news content publishers and syndicates, contracted software creators and coders, video postproduction services (such as editing, film/video transferring and formatting, subtitling, closed captioning, and special effects and animation), sound recording, editing and transferring services, Internet livestreaming, and content archiving. The next two largest upstream impacts of Amazon's entertainment businesses are:

- Just under \$40,000 to other local businesses in the Arts, Entertainment, and Recreation sector (NACIS 71), including to performing artists, groups and companies, podcast hosts, book authors and other independent artists, and their agents.
- Almost \$29,000 to local providers of Professional, Scientific, and Technical services (NACIS 54), which can include legal, accounting, bookkeeping, engineering, design, scientific research, technical consulting, advertising, public relations, photographic, and related services.

These upstream, indirect economic impacts of Amazon.com's business operations in these three areas – warehouse operations, grocery operations, and entertainment businesses – are per \$1 million of its own sales. The balance of economic impacts 'leak' to vendors outside the region, or else are received by Amazon's internal workforce in the form of wages and salaries.

Occupations of Amazon's Silicon Beach and Hollywood Workforce

Amazon.com's sprawling business operations fall into many different traditional industry sectors of the economy. Each of those industries consists of a variety of occupations – all of the different jobs that directly contribute to providing the services that Amazon offers its consumers. We use two sources of information to estimate the occupations of Amazon's labor force in its technology and entertainment offices, which highlight job positions it is currently filling, as well as its overall occupational composition.

Using Amazon's current jobs listings for the Los Angeles-area as a window onto its emerging occupations, the top full-time, non-fulfillment jobs include large numbers of software developers and data architects – which support most of the company's subsidiaries and services (*Figure 31*). "Solutions Architects," the second most common job listing, are software workers who create software code for Amazon Web Services (AWS) customers.

Figure 31: Amazon Technology and Entertainment Job Listings, Los Angeles Region

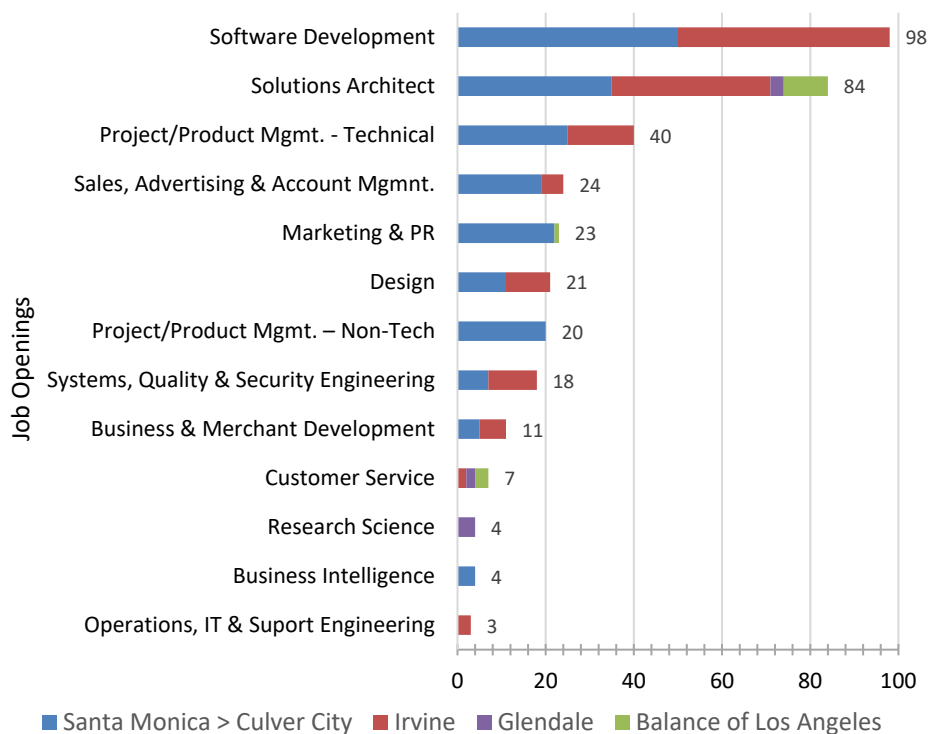

Sources: Amazon Jobs. <https://www.amazon.jobs/> Viewed November 13, 2019. Economic Roundtable analysis.

Other top job titles are those focused on sales, marketing, management and related professional services. The majority of these job posting are for the West Los Angeles offices, which are expected to be consolidated in Culver City in the coming years. Job listings are a mix of newly created jobs and jobs that other workers have left, creating a vacancy that the employer tries to fill. These data do not precisely represent the current or future workforce of Amazon, but offer an estimation.

We use U.S. Census Bureau’s *American Community Survey* to see the complete occupational composition of the Los Angeles region’s entertainment and technology industry sectors (*Figure 32*).⁵¹ The top four occupations are:

- *Entertainment and Media* jobs (37 percent), which includes artists, designers, actors, producers, directors, choreographers, reporters, news analysts, reporters, journalists, television, video, film camera operators and editors.
- *Computer and Mathematical* jobs (24 percent), such as computer systems and security analysts, computer and information research scientists, computer network support specialists, database and network administrators and architects, software and web developers, programmers, testers, statisticians and data scientists.

Figure 32: Employment by Occupation for Technology and Entertainment Industries

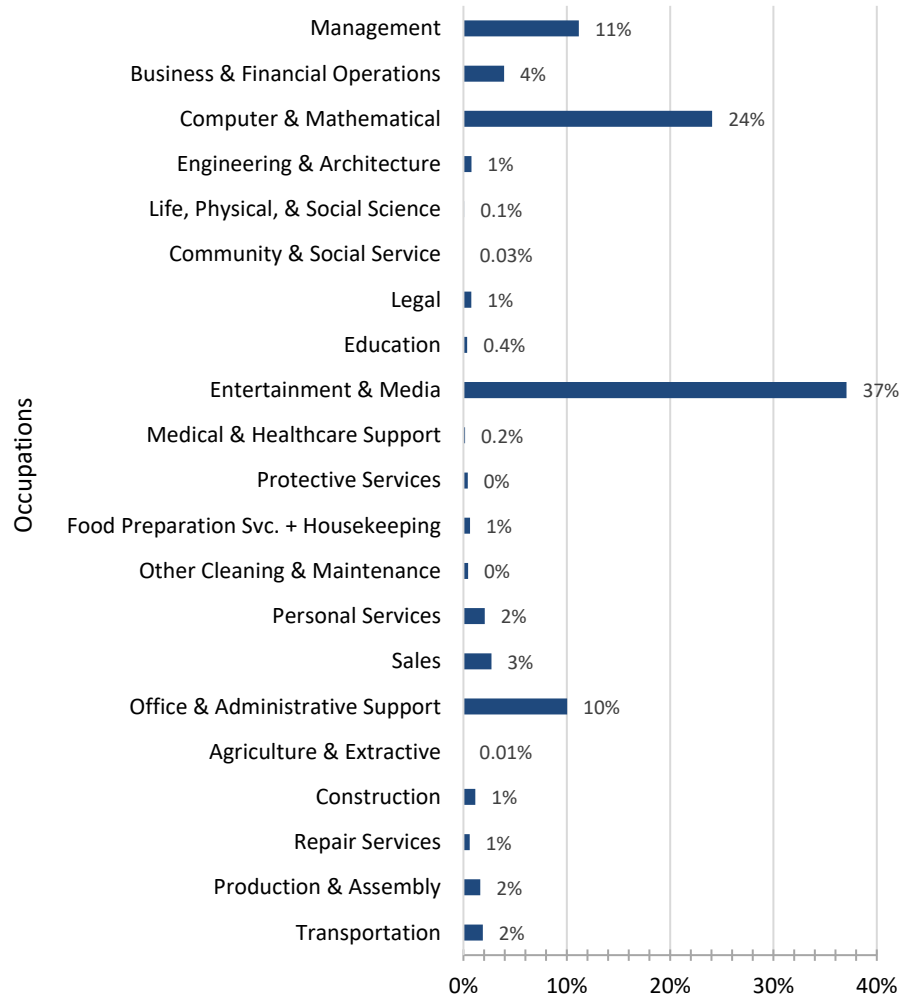

Sources: U.S. Census Bureau, 2017 5-Year American Community Survey, Public Use Microdata Set (PUMS), Occupational distribution for industries (INDP) 6480, 6490, 6570, 6590, 6672, 6695; Economic Roundtable analysis.

Business and project management occupations make up an estimated 11 percent of Amazon’s entertainment and technology jobs, while office and administrative support make up 10 percent. Numerous other occupational groups make up the balance of these industries’ work force, including food preparation service workers (1 percent).

Wages

Amazon’s jobs in its white-collar entertainment and technology sectors pay living wages. The median annual pay for Los Angeles County workers in these industries in 2017 was:

- Motion Pictures and Film \$47,789
- Entertainment \$47,789
- Gaming \$66,738

- Internet \$66,738
- Marketing and Advertising \$53,521
- Information Technology and services \$66,738
- Computer Software \$82,879

Summary

- Amazon employs an estimated 3,575 entertainment and technology employees in Los Angeles and Orange counties.
- Amazon procures products and services from nearly every industry in the four-county region but has the strongest industry linkages with other businesses in the real estate, information, shipping, waste management, and entertainment sectors.
- Amazon is recruiting large numbers of software developers and data architects in Los Angeles and Orange counties.
- The median annual pay for jobs in Amazon's non-warehousing industries ranges from roughly \$48,000 to \$83,333, providing a living wage for workers in those industries.
- Amazon workers employed in Silicon Beach and Hollywood in entertainment, computer and mathematics jobs make a living wage, typically earn enough to afford housing, buy Amazon products and enjoy a better standard of living than logistics workers.



Public Balance Sheet

Amazon's Annual Profit and Commitment to Employees

Amazon's growth and financial success during the past twenty years have broken records year after year. Their business strategy is explained in Jeff Bezo's *Letter to Stockholders* (2018 Annual Report) as focusing on maximizing *free cash flow* by aggressively growing sales revenue while managing costs and reinvesting profits.⁵² The company continues to succeed, with an annual compound sales growth rate from 1999–2018 of 25 percent.

In 2018 over \$13 billion of free cash flow was invested in infrastructure improvements and acquisitions. Net assets have increased annually, from \$8 billion in 2008 to \$163 billion in 2018.⁵³ This approach of reinvesting free cash in property and equipment has accelerated growth of company net worth, while keeping corporate income taxes low.⁵⁴ *Table 3* provides key financial details for 2014–2018.

Table 3: Amazon's Financial Growth 2014 to 2018

Amazon Financial Growth Millions of Dollars	2014	2015	2014-15 % Change	2016	2015-16 % Change	2017	2016-17 % Change	2018	2017-18 % Change
Revenue	\$88,988	\$107,006	20%	\$135,987	27%	\$177,866	31%	\$232,887	31%
Operating Income	\$178	\$2,233	1,154%	\$4,186	87%	\$4,106	-2%	\$12,421	203%
Net Income	(\$241)	\$596	347%	\$2,371	298%	\$3,033	28%	\$10,073	232%
Total Assets	\$53,618	\$64,747	21%	\$83,402	29%	\$131,310	7%	\$162,648	13%
Return on Assets – 4 th Qtr.	-0.57%	1.07%		3.38%		2.92%		7.11%	

This is what the accounting terms in *Table 3* mean:

- *Revenue* is income.
- *Operating Income* is profit after deducting operating expenses such as wages, depreciation, and cost of goods sold, but before interest and tax expenses are paid.
- *Net Income* is the amount of money left after all the expenses of a business have been subtracted from its revenue.
- *Total Assets* are everything that a business owns that has value and can be converted to cash.
- *Return on Assets* is *net income* divided by *total assets*. It shows how efficient a company is at using its assets to generate earnings.

Shareholders and employees with vested Amazon stock benefit the most from Amazon's aggressive strategies to grow revenues and net worth. The company's operating income is reinvested in purchasing property and equipment, supporting rapid growth and minimizing income tax obligations. This boosts Amazon's *stock price*, as shown in *Table 4*,⁵⁵ and its *return on assets* keeps growing, as shown in *Table 3*.

Shareholders and employees with vested Amazon stock benefit the most from Amazon's aggressive strategies.

Table 4: Growth in the Price of Amazon Stock 2014 to 2018

	2014	2015	2016	2017	2018
Average Stock Price	\$332.55	\$478.14	\$699.52	\$968.17	\$1,641.73
Annual % Change		44%	46%	38%	70%

Customers have also benefitted from Amazon’s operational excellence, with Amazon leading customer satisfaction polls year after year.⁵⁶ Overall, Amazon is extremely successful in accomplishing its business strategy.

Employees do the heavy lifting to achieve Amazon’s aggressive growth strategies, with no less lifting but fewer rewards for workers further down the wage ladder. Since Amazon’s founding Mr. Bezos has maintained a “Day One” startup culture, expecting employees to "remain vigilant and maintain a sense of urgency."

Reports from multiple employees suggest a relentless work environment with extremely high performance standards. Employee pay and benefits must make competitive sense and are considered below average for major high tech firms. Jeff Bezos, the CEO and president of Amazon, wants employees to “think like owners” and to work for longer term gains like stock options.⁵⁷

In the 2018 Annual Report, Jeff Bezos, expressed a strong “Commitment to Employees,” stating that it was fundamentally “the right thing to do” to pay all employees a minimum wage of \$15 per hour. He stated that Amazon Inc. was a company that uses “not just analysis but also intuition and heart to find our way forward.”

As upbeat as this sounds, Amazon also announced that it was eliminating bonuses and stock awards for fulfillment warehouse workers, so their net pay increase was less than what it appeared to be for longer-term warehouse workers who had previously received productivity bonuses. Many Amazon employees across the country were angered by the news.⁵⁸ A closer look at how Amazon manages its warehouses helps explain how it achieves its remarkable financial results.

Working Conditions in Amazon’s Warehouses

Amazon expects all employees to put in the long work days that are typical of a startup, including those in low-wage, entry-level jobs. Amazon warehouse jobs are grueling and high-stress. Warehouse workers wear tracking devices that management uses to monitor where there are at any time and how long it takes them to pick up each item. Those who can’t meet the assembly quotas are terminated.⁵⁹

The Atlantic magazine talked with workers at one San Bernardino warehouse who reported that workers could walk as much as 15 miles a day with scant time for bathroom or lunch breaks, and continuing pressure to work faster.⁶⁰ Many workers talked about the physical exhaustion of being on their feet all day, squatting and bending to retrieve packages.

Amazon intentionally creates a relentless work environment with extremely high performance standards.

Other reports confirmed that workers feel constant psychological stress from “...being held to the productivity standards of a robot...” With only 18 minutes off for bathroom breaks or getting a drink of water during 10+ hour shifts, many feel pressured to work through their breaks.⁶¹ Workers at multiple sites reported that productivity pressure was constant, with daily text messages about working faster.⁶²

Multiple workers reported worrying about being “written up” for failing to meet productivity standards, which is the first step toward getting fired. Only one day off is given to new hires, even for illness or deaths in the family. Because Amazon is located in communities where there are few jobs and prevailing wages are low, workers try to stick it out. Though they can slowly accrue more time off, lack of leave flexibility increases pressure, especially for working parents. Workers at several different sites said few employees last for longer than one year.⁶³

These working conditions reveal Amazon’s challenge. As America’s second-largest employer, “...they don’t want to be known as a bad employer, but they are an aggressive cost cutter.”⁶⁴ The workers and communities who create this profitability deserve a more equitable share of the rewards. This report concludes with a review of the actions Amazon needs to take to step up as a Corporate Citizen.

Amazon as a Corporate Citizen

Controversy has surfaced about Amazon’s scant corporate income tax payments and whether it is contributing adequately to the general welfare.⁶⁵

Amazon has paid less than 3% of its \$27 billion in profits for federal income tax.

Figure 33: Amazon Paid \$0.8 Billion in Taxes on \$27 Billion Profit, 2009-2018

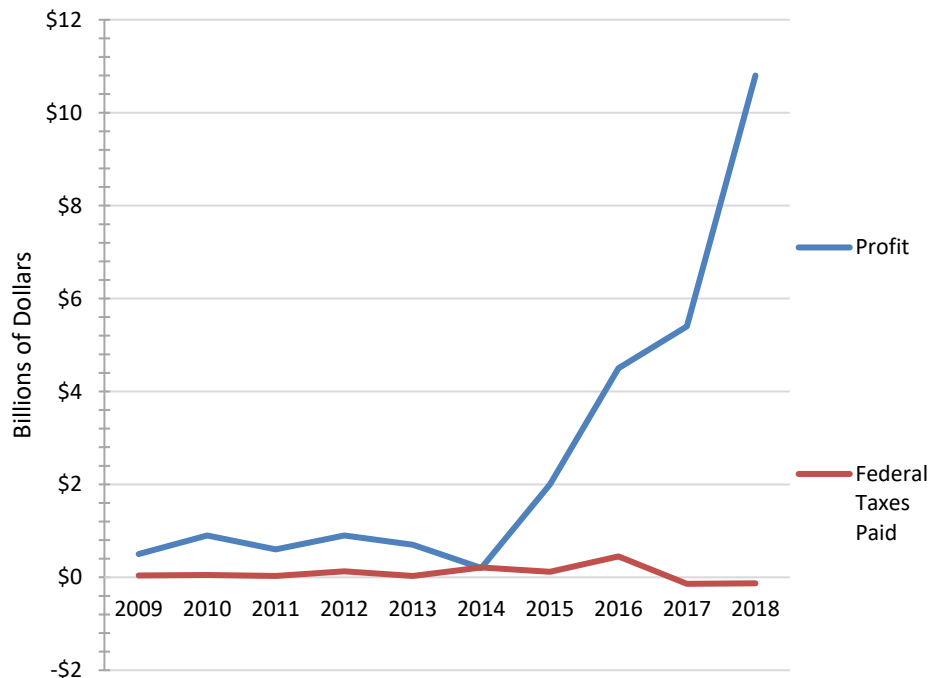

Source: Institute on Taxation and Economic Policy

Over the past decade, Amazon has paid less than three percent of its \$27 billion in profits for federal income tax, as shown in *Figure 33*.⁶⁶

American society expects that adults will pay their own way in the world, clean up their messes, and reciprocate what others do for them. These expectations are reasonable for corporate citizens as well.

Amazon has grown explosively as an autonomous, fresh thinking, hard driving organization that has taken maximum advantage of every freedom and opportunity allowed it. But it is no longer just an agile adventurer. Amazon is now a dominant force in shaping communities where its logistics operations are located and its workers live. It is restructuring industries, destroying brick-and-mortar retail jobs and replacing them with warehouse and delivery jobs.

This report has identified nearly \$850 million in public subsidies for Amazon and uncompensated social costs caused by Amazon in the four-county region, as shown in *Figure 34*. This is only a partial list. For example, it doesn't include the public costs to offset the wage deficits of underpaid delivery drivers employed by Amazon and its subcontractors.

Ninety-three percent of these subsidies, \$790 million, will recur year-after-year until Amazon raises wages and lowers greenhouse gas emissions. The

Amazon has received nearly \$850 million in public subsidies in the four-county region.

Figure 34: Public Subsidies for Amazon in the Four-County Region

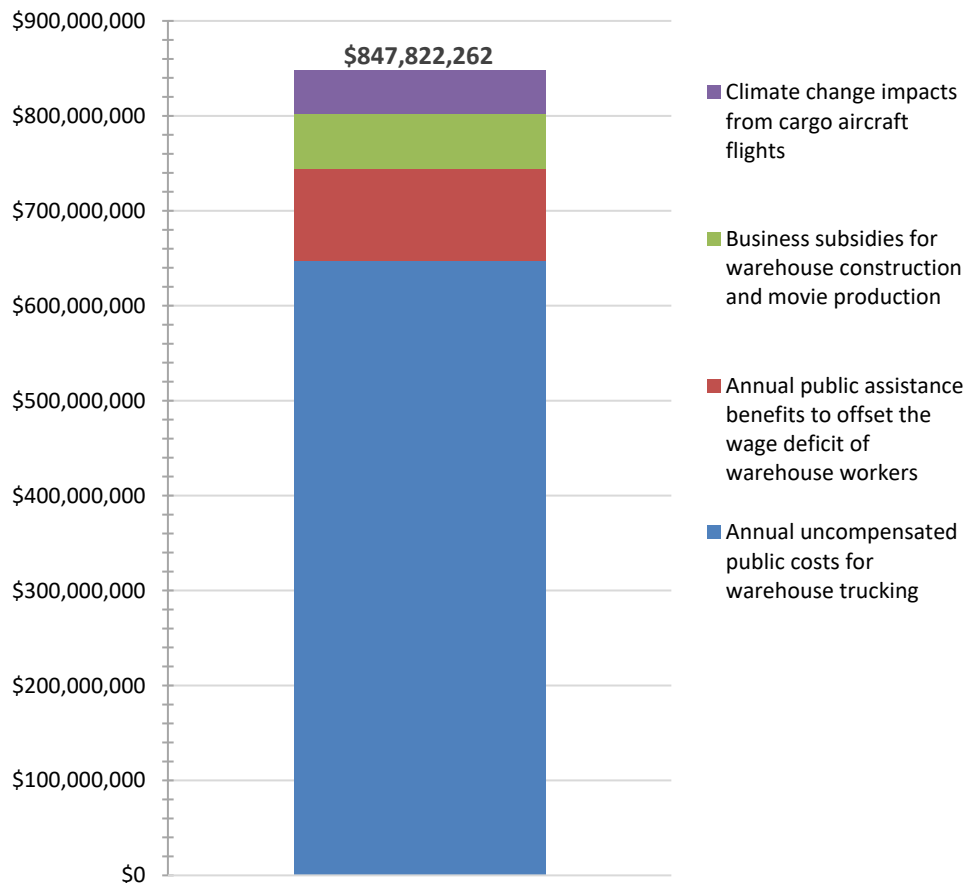

Source: *Economic Roundtable*

It is time for
Amazon to come
of age and pay its
own way.

remaining 7 percent, \$58 million, are one-time subsidies for building construction and movie production that could recur until policies change.

Amazon had an estimated \$7.5 billion in retail sales in the four-county region in 2018 and ended the year with over \$10 billion in corporate profit.

Amazon claimed that in 2018 it added over \$4 billion to the region's economy, including \$2 billion for "infrastructure, security, utilities and operating expenses, including employee salaries...The other \$2.7 billion made its way to local caterers, gas stations, grocery stores, restaurants, sign makers and industrial supply firms."⁶⁷ The analysis of jobs in this report demonstrates, instead, that Amazon's thousands of blue collar workers lack sustainable incomes and require public subsidies to survive.

Phaeton (*cover image*) did not know his limits, overreached and fell to his own destruction. Amazon can avoid this fate by finding its footing as an equitable community partner and continue to rise both as an economic success and a corporate citizen.

It is time for Amazon to come of age and pay its own way. This means paying its full costs to the communities that host it and the workers who create its profits. Amazon will benefit when its workers have living incomes because they will have the buying power to purchase the products it sells.

Recommendations

Based on the findings in this report, the Economic Roundtable makes the following nine recommendations for achieving equity in Amazon's logistics operations:

1. Pay a minimum wage of \$20 an hour, adjusted annually for cost of living changes, to provide a living income for warehouse workers and delivery drivers.
2. Provide comprehensive and affordable health insurance for warehouse workers and delivery drivers and their families, eliminating the need for workers and their families to rely on publicly subsidized Medi-Cal health insurance.
3. Provide work breaks for warehouse workers that enable them to remain hydrated, use bathrooms and eat mid-shift meals.
4. Provide affordable child care onsite or at nearby child care centers.
5. Require logistics subcontractors to provide the same wage floor and benefits as Amazon.
6. Invest Amazon's assets in building affordable housing in communities where its logistics facilities are located as well as the communities where employees from those facilities live.

7. Become a partner in local, regional and statewide initiatives to raise the wage floor for the entire logistics sector so that all warehouse, trucking and delivery companies meet the same standards of civic responsibility as Amazon.
8. Step up as a leader in reducing climate change impacts by deploying zero emission vehicles and disclosing its full carbon footprint.
9. Collaborate in improving and expanding the scope of impact estimates provided in this report to support analysis, planning and policies for reducing the costs and increasing the benefits of the services Amazon provides.

End Notes

¹ Ladd, Jonathan M., Joshua A. Tucker, and Sean Kates (2018), *2018 American Institutional Confidence Poll: The Health of American Democracy in an Era of Hyper Polarization*,” The Baker Center for Leadership and Governance, Georgetown University: <http://aicpoll.com/>

² Newton, Casey, Nick Statt, and Michael Zelenko (October 27, 2017). “The Verge Tech Survey,” *The Verge*, <https://www.theverge.com/2017/10/27/16550640/verge-tech-survey-amazon-facebook-google-twitter-popularity>

³ La Monica, Paul R. (January 8, 2019), “Amazon is now the most valuable company on the planet,” *CNN Business*, <https://www.cnn.com/2019/01/08/investing/amazon-most-valuable-company-microsoft-google-apple/index.html>

⁴ This is a conservative estimate based on the four-county region of Los Angeles, Orange, Riverside and San Bernardino accounting for 5.3 percent of U.S. household income, according to Table B19025 of the U.S. Census Bureau’s American Community Survey. This region is a national hub for logistics and entertainment content, so it may well generate a substantially greater share of Amazon’s revenue. This estimate does not include data for cloud computing services and assumes that L.A.’s level of consumption of those services is comparable to other U.S. regions.

⁵ Dun & Bradstreet (September 25, 2018), Amazon.com, Inc., Company Description, <https://www.dnb.com/>

⁶ 2018 Amazon Annual Report, page 4, <https://ir.aboutamazon.com/annual-reports>.

⁷ Introductory letter to shareholders, 2018 Amazon Annual Report, page 6.

⁸ Johnson, Eric, “Amazon’s full impact on container shipping emerging,” *JOC.com* (February 22, 2019), https://www.joc.com/international-logistics/logistics-providers/amazon%E2%80%99s-full-impact-container-shipping-emerging_20190222.html.

⁹ “Amazon Air” (2019), Wikipedia, https://en.wikipedia.org/wiki/Amazon_Air.

¹⁰ Levi, Ari (April 25, 2019), “Amazon Web Services revenue grew 41% in the first quarter,” CNBC News, <https://www.cnbc.com/2019/04/25/aws-earnings-q1-2019.html>

¹¹ Harwell, Drew (October 23, 2018), “Amazon met with ICE officials over facial-recognition system that could identify immigrants,” Washington Post, <https://www.washingtonpost.com/technology/2018/10/23/amazon-met-with-ice-officials-over-facial-recognition-system-that-could-identify-immigrants/>

¹² Novak, Matt (January 31, 2018), “Amazon Patents Wristband to Track Hand Movements of Warehouse Employees,” *Gizmodo*, <https://gizmodo.com/amazon-patents-wristband-to-track-hand-movements-of-war-1822590549>

¹³ This estimate of Amazon revenue derived from the four-county region was derived from the Consumer Expenditure Survey, U.S. Bureau of Labor Statistics, September, 2018, Table 1203, “Income before taxes: Annual expenditure means, shares, standard errors, and coefficients of variation.” This table breaks households out into nine income groups and provides expenditure amounts for a detailed list of items purchased by

households in each income group. Items in this list that are sold by Amazon were flagged and totaled for each income group. These expenditure by income group were then applied to census-tract-level breakouts of household income, and then adjusted downward for each census tract so that the total for all four counties equaled Amazon's estimated total of \$7.2 billion in retail sales in the region (which was derived by applying the region's share of U.S. household income to Amazon's U.S. retail sales). This last downward adjustment was needed because the same items purchased from Amazon are also purchased from in-store retailers in the region, which account for a majority of sales for these items.

¹⁴ Statista (February 5, 2019), <https://www.statista.com/statistics/266289/net-revenue-of-amazon-by-region/>

¹⁵ Whole Foods Newsroom (2019), <https://media.wholefoodsmarket.com/>

¹⁶ Statista (August 9, 2019), data is for 2017, <https://www.statista.com/statistics/258673/net-sales-of-whole-foods-market-worldwide/>

¹⁷ Assessor records and other public data sources show 15,109,226 square feet of space in warehouses currently occupied by Amazon. We estimate that there is one daily diesel truck trip per 702 square feet of warehouse space, or a total of 21,523 daily diesel truck trips for Amazon warehouses in the four counties. This estimate is taken from the City of Fontana's environmental impact report for the Southwest Fontana Logistics Center Project, "Final Environmental Impact Report, State Clearinghouse No. 2016091057," page 13. Prepared by: LSA Associates, Inc., November 21, 2017. *This clarification was added to the report on November 29, 2019: total truck trips is the sum of trips ending when trucks arrive at warehouses and also trips beginning when trucks depart from warehouses.*

¹⁸ Assessor records and other public data sources show 15,109,226 square feet of space for every 814 square feet of warehouse space, or a total of 18,562 workers currently employed at Amazon warehouses in the four counties. This estimate is taken from the City of Fontana's environmental impact report for the Southwest Fontana Logistics Center Project, "Final Environmental Impact Report, State Clearinghouse No. 2016091057," page 7. Prepared by: LSA Associates, Inc., November 21, 2017.

¹⁹ Amazon.com (2019), "How your package gets from Amazon's warehouse to your front door," <https://www.aboutamazon.com/amazon-fulfillment/our-fulfillment-centers/how-your-package-gets-from-amazons-warehouse-to-your-front-door/>

²⁰ U.S. Congressional Budget Office (October 17, 2019), "Issues and Options for a Tax on Vehicle Miles Traveled by Commercial Trucks," <https://www.cbo.gov/publication/55688>

²¹ Uncompensated public costs from truck travel are costs that exceed the revenue collected from heavy-vehicle use tax, tax on tires, fuel tax, and vehicle registration fees for trucks and trailers. Austin, David (March 2015), Congressional Budget Office, "Pricing Freight Transportation to Account for External Costs," Working Paper 2015-03, <https://www.cbo.gov/publication/50049>. Uncompensated public costs from truck noise is from U.S. Department of Transportation, Federal Highway Administration, (May 2000) "Addendum to the 1997 Federal Highway Cost Allocation Study Final Report," <https://www.fhwa.dot.gov/policy/hcas/addendum.cfm>

²² U.S. National Library of Medicine (May 31, 2017), "Nitrogen Oxides," <https://toxtown.nlm.nih.gov/chemicals-and-contaminants/nitrogen-oxides>

²³ Healthline (August 5, 2016), "The Dangers of Smog: What You Need to Know About Air Pollution," <https://www.healthline.com/health/dangers-smog-what-you-need-know-about-air-pollution>

²⁴ California Air Resources Board (accessed November 22, 2019), “Overview: Diesel Exhaust & Health,” <https://ww2.arb.ca.gov/resources/overview-diesel-exhaust-and-health>

²⁵ Interagency Working Group on Social Cost of Greenhouse Gases, United States Government (August 2016), Technical Support Document: Technical Update of the Social Cost of Carbon for Regulatory Impact Analysis Under Executive Order 12866, page 4. The average value for 2020 was used with a 2.5 percent discount rate to reflect current economic trends, 2007 dollars were adjusted to 2017 dollars to be consistent with other cost and wage data in the report, using the CPI factor of 1.178855 for the Los Angeles region. These adjustments identified a social cost of \$73 per metric ton. file:///D:/My%20Documents/Articles/Environment/Technical%20Update%20of%20the%20Social%20Cost%20of%20Carbon%20for%20Regulatory%20Impact%20Analysis%20-%20U.S.%20Interagency%20Working%20Group%20sc_co2_tsd_august_2016.pdf

²⁶ The number of warehouse workers is based on the ratio of one workers per 814 square feet of warehouse space. The number of truck drivers is based on one truck trip with the equivalent of a 20’ container per 702 square feet of warehouse space, and two round trips per day from the Port of Long Beach to warehouses based on distance and travel time. The number of last-mile deliver drivers is based on the four-county region accounting for 5.3 percent of the 13 billion packages Amazon delivered in the U.S. in 2018, and number of packages delivered per day per driver being the mid-range between 200 reported by Amazon and 100 reported by drivers. Buchholz, Katharina (November 8, 2019), “87 Billion Parcels were Whipped in 2018,” Statista, <https://www.statista.com/chart/10922/parcel-shipping-volume-and-parcel-spend-in-selected-countries/>

²⁷ The estimated number of truck drivers represents two round trips per driver per day, and is based on the travel time from the Port of Long Beach to each warehouse. The estimated number of delivery drivers is based on two round trips per driver per day, which requires an average of more than eight hours per day.

²⁸ The estimate of packages delivered is derived from the four-county region representing 5.3 percent of U.S. household consumption, and Statista reported that Amazon delivered 13 billion packages in the U.S. in 2018, Statista, <https://www.statista.com/chart/10922/parcel-shipping-volume-and-parcel-spend-in-selected-countries/>

²⁹ Premack, Rachel (June 11, 2019), “FedEx no longer will fly your Amazon packages - and now pressure is mounting on the company as it gears up its in-house air-freight network,” Business Insider, <https://www.businessinsider.com/fedex-amazon-one-day-delivery-2019-6>

³⁰ Kaplan, Deborah Abrams (June 6, 2017), “The real cost of e-commerce logistics,” SupplyChain, <https://www.supplychaindive.com/news/amazon-effect-logistics-cost-delivery/444138/>

³¹ Shipware (August 26, 2018), “What is Last Mile Logistics,” <https://www.shipware.com/what-is-last-mile-logistics/>

³² Dolan, Shelagh (May 10, 2018), “The Challenges of Last Mile Logistics and Delivery Technology Solutions,” Business Insider, <https://www.businessinsider.com/last-mile-delivery-shipping-explained>

³³ Statista reported that Amazon delivered 13 billion e-commerce packages and had revenue of \$119 billion in the U.S. in 2018, Statista, <https://www.statista.com/chart/10922/parcel-shipping-volume-and-parcel-spend-in-selected-countries/>

³⁴ Longitudinal Employer-Household Dynamics (LEHD) program of the U.S. Census Bureau provides a profile of workers employed on each census block. Most Amazon warehouses cover a census block. The most recent data is for 2017. This data was used to profile warehouse workers. This data also provides a breakout of all of the residential census blocks where workers employed on a given census block live. This residential breakout was used to identify where workers employed in Amazon warehouses live.

³⁵ The categorical information from LODES provides only a baseline description of warehouse workers. To access detailed economic, housing, social, and demographic data to describe the living conditions of warehouse workers we incorporated data from the Public Use Microdata Sample (PUMS) of the American Community Survey (ACS) of the U.S. Census Bureau. ACS reaches approximately a five percent sample of the U.S. population over a five-year period. Over 200 variables are measured, including number of hours worked, housing cost burden, and number of people and rooms per household. The unit of geography for these records is Public Use Microdata Areas (PUMAs). Each PUMA contains no fewer than 100,000 people. PUMAs are large enough to provide detailed information about individuals without compromising their privacy, but small enough to be relatively homogenous. Although we are not able to isolate Amazon warehouse workers from PUMS data, we restricted and weighted this data to correspond as closely as possible with those workers. To do this we used information from LODES about workers on Amazon warehouse footprints as a baseline for re-weighting. We included only PUMS records for individuals work in NAICS 493 industry classification, Warehousing and Storage, and only workers in line occupations, that is, occupations that were not managerial, supervisory, or professional. PUMS records were re-weighted so that on aggregate the distribution of entries had the same proportion of individuals in each geographic area as the LODES data. The re-weighted PUMS records were tested to confirm that they matched the age and income distribution of LODES records for Amazon warehouse workers.

³⁶ Employment Law Handbook (2018), <https://www.employmentlawhandbook.com/federal-employment-and-labor-laws/aca/>

³⁷ Amazon (October 2, 2018), “Amazon Raises Minimum Wage to \$15 for All U.S. Employees,” <https://blog.aboutamazon.com/working-at-amazon/amazon-raises-minimum-wage-to-15-for-all-us-employees>

³⁸ Soper, Spencer (October 3, 2018). "Amazon Warehouse Workers Lose Bonuses, Stock Awards for Raises," Bloomberg.com, <https://www.bloomberg.com/news/articles/2018-10-03/amazon-eliminating-bonuses-stock-awards-to-help-pay-for-raises>

³⁹ U.S. Census Bureau (January 2014), American Community Survey Design and Methodology, Chapter 4: Sample Design and Selection, https://www2.census.gov/programs-surveys/acs/methodology/design_and_methodology/acs_design_methodology_ch04_2014.pdf

⁴⁰ Whitehead, Brian (October 31, 2017), “How San Bernardino County hopes to lure a second Amazon headquarters,” The Sun, <https://www.sbsun.com/2017/10/31/san-bernardino-county-shares-proposal-to-lure-second-amazon-headquarters/>

⁴¹ Stokley, Sandra (May 24, 2014), “EASTVALE: Residents riled about warehouse complex.” The Press-Enterprise, <https://www.pe.com/2014/05/24/eastvale-residents-riled-about-warehouse-complex/?returnUrl=https://www.pe.com/2014/05/24/eastvale-residents-riled-about-warehouse-complex/?clearUserState=true>

⁴² Cano, Alejandro (January 24, 2018), “Huge warehouse, park project approved by Fontana City Council,” Herald News, https://www.fontanaheraldnews.com/news/huge-warehouse-park-project-approved-by-fontana-city-council/article_ed20aa2c-0171-11e8-8eda-9fed77bb8826.html

- ⁴³ Avdis, Panorea, Director of the California Governor’s Office of Business and Economic Development (May 25, 2016), <https://caled.org/amazon-continues-expand-golden-state/>
- ⁴⁴ Amazon (2019), <https://www.amazon.jobs/en/locations/irvine-california>
- ⁴⁵ Southwest Fontana Logistics Center Development Agreement between the City of Fontana, a California municipal corporation, and GLC Fontana II, LLC, a Delaware Limited Liability Company (January 23, 2018), Exhibit A, page 12.
- ⁴⁶ City of Beaumont Rolling Hills (Crossroads Logistics) Fee Credit Agreement, by and among the City of Beaumont, a municipal corporation organized and existing under the laws and Constitution of the State of California, hereinafter referred to as " City" and USEF Crossroads II, LLC, a Delaware limited liability company, with its principal place of business at 9830 Colonnade Blvd., Suite 600, San Antonio, Texas, 78230, hereinafter referred to as " Property Owner," (February 5, 2019), Exhibit F.
- ⁴⁷ The Times Editorial Board (September 12, 2019), “Editorial: Enough with the corporate welfare. California can stop the tax-break arms race,” Los Angeles Times, <https://www.latimes.com/opinion/story/2019-09-11/no-tax-sharing-bill-amazon-california>
- ⁴⁸ Rojas, Alec. 2017. “A Brief History of Amazon Web Services (AWS),” Media Temple. August 31, 2017 <https://mediatemple.net/blog/news/brief-history-aws/> Viewed October 13, 2019.
- ⁴⁹ Fritz, Ben. 2010. “Amazon.com going into movie producing with new website, first look deal with Warner Bros.” *Los Angeles Times*. November 16, 2010. <https://latimesblogs.latimes.com/entertainmentnewsbuzz/2010/11/amazoncom-going-into-movie-producing-with-new-website-first-look-deal-with-warner-bros.html> Viewed October 13, 2019.
- ⁵⁰ Weise, Elizabeth. 2018. “Amazon is no longer a Seattle company. Here's what that will mean for future workers and its second headquarters” *USA Today*, August 13, 2018. <https://www.usatoday.com/story/tech/news/2018/08/13/hq-2-second-headquarter-not-seattle/663283002/>
- ⁵¹ The U.S. Census Bureau’s *American Community Survey* industry sectors (INDP) analyzed in this section include the following, combined:
- | Code | Industry Description |
|------|---|
| 6480 | Periodical, book, and directory publishers |
| 6490 | Software publishing |
| 6570 | Motion pictures and video industries |
| 6590 | Sound recording industries |
| 6672 | Internet publishing and broadcasting and web search portals |
| 6695 | Data processing, hosting, and related services |
- ⁵² Bezos, Jeff (2019), *Letter to Shareholders*, 2018 Amazon Annual Report, <https://ir.aboutamazon.com/annual-reports>
- ⁵³ Macrotrends, Amazon Inc., Financials, <https://www.macrotrends.net/stocks/charts/AMZN/amazon/total-assets>
- ⁵⁴ Macrotrends, Amazon, Inc, Financials, <https://www.macrotrends.net/stocks/charts/AMZN/amazon/financial-statements>
- ⁵⁵ Macrotrends, Amazon, Inc, Financials, <https://www.macrotrends.net/stocks/charts/AMZN/amazon/stock-price-history>

- ⁵⁶ Morgan, Blake (August 21, 2019), “Amazon – 2019, 3rd Q Earnings Report; Ways Amazon and Walmart Compete: A look at the Numbers,” Forbes, <https://www.forbes.com/sites/blakemorgan/2019/08/21/amazon-versus-walmart-goliath-versus-goliath/#2d587a194674>
- ⁵⁷ Corporate Culture Pros (2019), Amazon’s corporate culture: A balanced view, <https://www.corporateculturepros.com/amazons-corporate-culture/>
- ⁵⁸ Soper, Spencer (October 3, 2018). "Amazon Warehouse Workers Lose Bonuses, Stock Awards for Raises," Bloomberg.com, <https://www.bloomberg.com/news/articles/2018-10-03/amazon-eliminating-bonuses-stock-awards-to-help-pay-for-raises>
- ⁵⁹ Roosevelt, Margot, (Oct. 3, 2018), LA Times, Amazon’s \$15 minimum wage gives a lift to California’s vast warehouse region, <https://www.latimes.com/business/la-fi-amazon-minimum-wage-20181002-story.html>; Edwards, Jim (August 5, 2013). "Brutal Conditions In Amazon's Warehouse's Threaten To Ruin The Company's Image". *Business Insider*. Retrieved February 24, 2014.
- ⁶⁰ Semuels, Alana (February 1, 2018), “What Amazon Does to Poor Cities,” The Atlantic, <https://www.theatlantic.com/business/archive/2018/02/amazon-warehouses-poor-cities/552020/>
- ⁶¹ Guendelsberger, Emily (July 18, 2019), TIME, “I Worked at an Amazon Fulfillment Center”; They Treat Workers Like Robots”, <https://time.com/5629233/amazon-warehouse-employee-treatment-robots/>; We are not robots. Sainato, Michael (January 2019), <https://www.theguardian.com/technology/2019/jan/01/amazon-fulfillment-center-warehouse-employees-union-new-york-minnesota>
- ⁶² Long, Heather, (Oct. 5, 2018), The Washington Post, “Amazon’s Minimum Wage Doesn’t End Debate Over Whether It Is Creating Good Jobs”, https://www.washingtonpost.com/business/economy/amazons-15-minimum-wage-doesnt-end-debate-over-whether-its-creating-good-jobs/2018/10/05/b1da23a0-c802-11e8-9b1c-a90f1daae309_story.html
- ⁶³ Áine Cain and Isobel Asher Hamilton, (Feb. 19, 2019), Business Insider, “Amazon warehouse employees speak out about the 'brutal' reality of working during the holidays, when 60-hour weeks are mandatory and ambulance calls are common”, <https://www.businessinsider.com/amazon-employees-describe-peak-2019-2>; Semuels, A., op. cit; Roosevelt, op. cit.
- ⁶⁴ Long, H., *op. cit.*
- ⁶⁵ Ingraham, Christopher (February 16, 2019), Washington Post, *Amazon paid no federal taxes on \$11.2 billion on profits last year*, <https://www.washingtonpost.com/us-policy/2019/02/16/amazon-paid-no-federal-taxes-billion-profits-last-year/>
- ⁶⁶ Gardner, Matthew (February 13, 2019), “Amazon in Its Prime: Doubles Profits, Pays \$0 in Federal Income Taxes,” Institute on Taxation and Economic Policy <https://itep.org/amazon-in-its-prime-doubles-profits-pays-0-in-federal-income-taxes/>
- ⁶⁷ Smith, Kevin (April 27, 2018), “Amazon says it invested \$4.78 billion in the Inland Empire,” San Gabriel Valley Tribune, <https://www.dailybulletin.com/2018/04/27/amazon-says-it-invested-4-7-billion-in-the-inland-empire/>